

AQUAPONICS CONSTRUCTION – DEMONSTRATION SYSTEM AT CAMPUS ROSLAGEN, SWEDEN

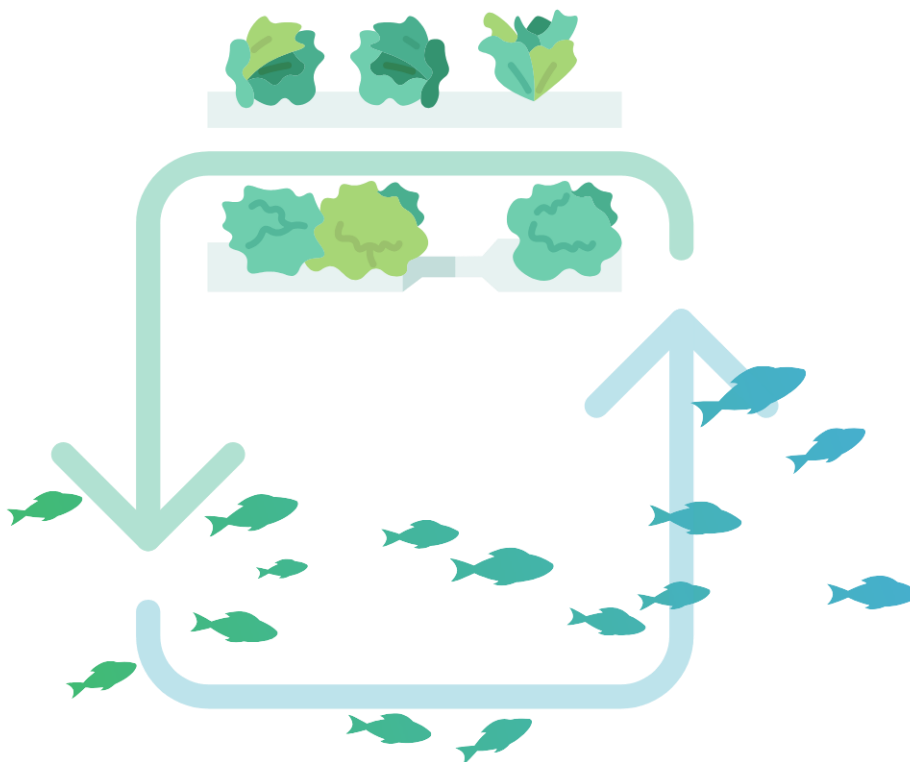

1 Index

1. Introduction	3
1.1 TransFarm project	3
1.2 Purpose of this report	4
2 Construction principles	5
2.1 Growing beds and Sump	5
2.2 Fish tank	8
3 Materials	9
3.1 Wood.....	9
3.2 Plastics.....	10
3.2.1 PVC	10
3.2.2 PP	10
3.3 General concerns	10
4 Water flow chart and setup	10
4.1 Reduction of flood risk	12
5 Ebb/flood system design and construction.....	13
6 Back-up system.....	15

1. Introduction

1.1 TransFarm project

There are several environmental and social challenges that the food sector has to face: Agriculture is a sector particularly affected by climate change, our seas are overfished and the world population is estimated to continue growing, being about 9,7¹billion people by 2050.

Countries in the Baltic Sea Region are strongly dependent on food import, especially for vegetables, fruit and fish; in recent years the pandemics and the war in Ukraine have exposed the need of more self sufficient food systems. Moreover, agriculture and aquaculture are among the main contributors to the eutrophication of the Baltic Sea.

To answer these challenges TransFarm project wants to bring food production closer to consumers by promoting soil-less farming methods that can be implemented even indoors and allow to grow all year round. Examples of these methods are hydroponics, where plants are grown in water, and aquaponics, that combines hydroponics with aquaculture.

Aquaponics is a circular, closed-loop system, where water from the fish culture is used to grow plants. The fish waste within the water is microbiologically transformed by a biofilter, absorbed by plants and then cleaner water returned to the fish. The system is completely circular allowing nutrient reuse without emissions of nutrients in the environment. Since the fish, plants and microorganisms in an aquaponics system function in close symbiotic relationship, antibiotics or pesticides are not used, which in turn provides cleaner, healthier produce.

TransFarm will demonstrate aquaponics in Sweden, Estonia and Latvia as well as test alternative water sources such as rainwater and reclaimed greywater: Partners from these countries will build demonstration facilities with different characteristics and aims. The experiences exchange from the different demos will contribute to knowledge co-creation and the facilities will be the opportunity to inspire and educate future aquaponics farmers. The knowledge gathered from the construction and monitoring of the demos will result in education material available for all the actors interested in aquaponics.

The project will also investigate business models, run activities to inform consumers about the quality of the aquaponics produce, educate entrepreneurs that want to start an aquaponics system as well as inform civil servants and policy makers about the reduced environmental impact of circular soil-less farming methods.

¹ UN DESA publications – World population prospects 2022

TransFarm project duration is three years (2023-2026) and it is coordinated by Turku School of Economics at the University of Turku (Turku, Finland). Project partners are the Estonian University of Life Sciences (Tartu, Estonia), University of Latvia (Riga, Latvia), Campus Roslagen, Companion Roslagen & Norrort and Norrtälje Vatten och Avfall (Norrtälje, Sweden).

TransFarm project is funded by EU's Interreg Central Baltic program, the total budget of the project is 1,87 million euro, EU financing covers 1,5 million euro.

1.2 Purpose of this report

The present report describes how the aquaponics demonstration system at Campus Roslagen was constructed during the Transfarm project. The report is meant to serve as an example of how Aquaponic systems could be constructed and will hopefully be a source of inspiration and ideas when other aquaponics systems is being planned. Every site has its own set of conditions and options, and constructors differs in skills and preferred materials. When planning a new Aquaponics system, looking in to different construction principles and comparing them will hopefully make a suitable and preferred construction principle take form.

The demonstration facility at Campus Roslagen consists of a small-scale aquaponic system, an investigatory trial of hydroponics in treated greywater², and a system for rainwater harvesting. The construction principles of the small-scale aquaponic system is described in this report, the construction of the trial with treated graywater is described separately in a report similar to this one.

A more thorough description in designing a system and the vital features can be found in the TransFarm report ***Aquaponics demo design – demonstration system at Campus Roslagen, Sweden*** (referred to as *Report Design* in this report). In this report there are a few sections identical to sections in the *Report Design*, as the two reports to some extent overlap. We are hoping for the leniency of the readers regarding this duplication.

² Wastewater from non-toilet plumbing systems, i.e. from sinks, showers, etc.

2 Construction principles

Report Design describes how the facility of the demo was selected and how the demo was dimensioned (chap. 3 and 4).

In order to fit a demo as big as possible in the room as well as keeping the construction costs down, the choice was made to build most of the system parts on site. Some level of construction skill is needed if one is to construct the system by himself, but on the other hand it makes it possible to choose very site- and system-specific dimension and gives a greater understanding of the system and its parts.

2.1 Growing beds and Sump

Neither the DCW, the Media bed nor the sump required high water levels, which allows for a bit less robust construction. In a construction supposed to contain deep water, the pressure on the walls is remarkable. In these beds a depth of 30-40 cm is sufficient, making the construction less challenging.

The construction principle of these parts of the system is a wooden frame (45*70mm) supporting a plywood plate (12mm). Inside of this construction a rubber liner (EPDM, sold as underlayment for fish or koi ponds) keeps the construction water sealed.



Figure 1. Wooden frame and plywood

A plywood with water resilient coating were used, but we believe that uncoated plywood could have been used since it is not exposed to water splashes or excessive moisture. Untreated wood was used for the framing, and no growth has been observed. The construction does not stand directly on the

floor, underneath every leg of the construction there are pieces of plastic elevating the legs at least 5 mm to prevent contact with water (in case of flooding or temporary puddles on the floor) and allowing for levelling adjustment since the floor is not completely horizontal.



Figure 2. Rubber liner fastened in DWC

The rubber liner inside the construction was fastened by clamping it to the structure with slim wooden boards (25*35 mm) fastened with screws. It is vital not to pierce the rubber lining below the water level.

The only hole in the lining needed is for the outlet. We used a screwable fitting in PVC delivered with a rubber gasket (bought from the same garden pond webshop as the rubber lining and several of the air- and water pumps) that fits 50 mm pipes. To the outlet fitting a small piece of 50 mm PVC-pipe was glued, but the rest of the piping consists of PP sewage pipes that are cheaper, more easily available, and detachable in case of reconstruction or placement adjustments. The choice of materials is further discussed in chapter 3.



Figure 3. outlet fitting glued to 50mm PVC pipe



Figure 4. outlet fitting through rubber lining

The DWC, the Biobeds and the Sump in the demo are all constructed in accordance with this principle, with the exception that the Sump does not have an outlet pipe. The design features and purpose of the Sump (including biofilter and mechanical filter) is thoroughly described in the *Report Design*.

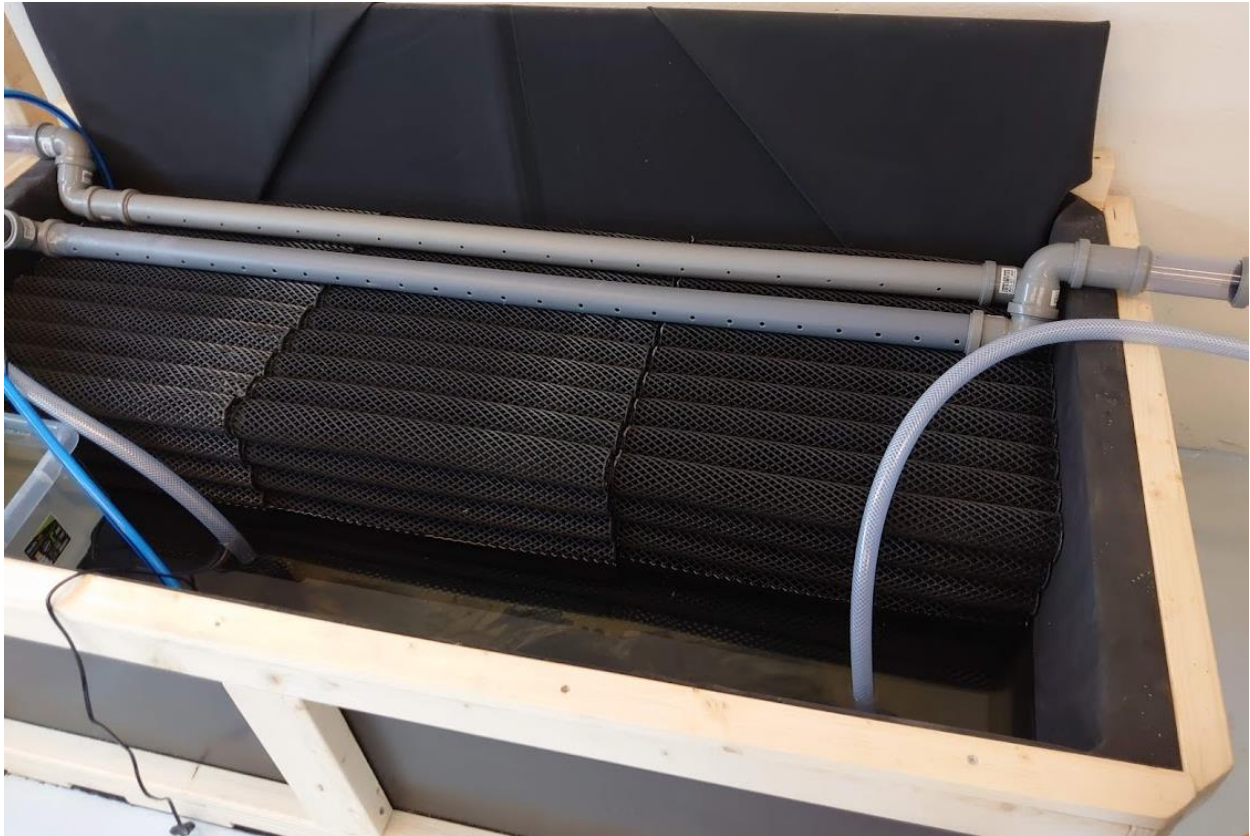

Figure 5. Sump containing pumps and biofilter

2.2 Fish tank

We decided not to build the fish tank on site but instead buy a prefabricated tank since the water depth of the tank would be greater than in the growing beds (higher water pressure), and food-graded tanks in suitable sizes are available at reasonable costs.

The tank installed in the demo at Campus Roslagen is a storage tank from Cipax, with a diameter of 160 cm. The tank was cut to a height of 88 cm in order to fit through the door and an outlet pipe was welded to the tank at a height of 72 cm from the bottom. When designing the system, we decided that it was preferable to have the outlet as high as possible rather than deep because of accessibility and reduced risk of leakages.

Faeces and excess feed residues tend to sink to the bottom of the fish tank. Incoming water is pumped and released close to and perpendicular to the wall of the tank, causing a stream and a slow rotation of the water in the tank. This rotation concentrates the residues in the centre of the (bottom of the) tank. By connecting a pipe from the outlet to the bottom centre of the tank, faeces and feed residues exits the tank. A larger diameter (110 cm) of the centre pipe reduces the risk of clogging. By connecting it to a Y-pipe at the outlet, an overflow possibility was added, should the centre pipe getting clogged.



Figure 6. Fish tank during construction. Water exits the tank from the bottom of the tank, by rising through the red pipe, the grey Y-pipe, the black pre-welded outlet and back to the sump. The inlet water hose in the picture is a very temporary setup during construction and should not be considered a recommendable installation.

3 Materials

When constructing an aquaponic system, the impact of the materials must be considered. The well-being of the fish and production of safe food is of the essence when choosing materials. Non-toxic and food graded material should be chosen for most applications.

3.1 Wood

Wood is a cheap and easily processed natural material, but it can deteriorate and provide habitat for bacteria and mold when wet. Chemically treated wood (impregnated by pressure-treatment) is commonly used in outdoor constructions in wet or damp environments, but the toxins it contains in order to repel mold makes it unsuitable to use in contact with the water in an aquaponic system. Since neither pressure-treated wood (due to toxins) nor non-treated wood (due to mold, bacteria and decomposition) is recommendable in contact with water, wood is only usable where water contact is avoidable.

If there is no contact with water, non treated wood will do just fine, and the toxins in pressure treated

wood can be avoided completely, reducing the risk of air-borne residues and negative impact of hazardous waste produced.

3.2 Plastics

Plastic is a very usable material since it is waterproof, lightweight and relatively easy to process. Pipes, tubes and hoses are almost always plastic. There are several different plastics available, with different properties and risks involved. The two most commonly used types of plastics is Polypropylene (PP) and Polyvinyl Chloride (PVC). Different plastics can generally not be glued to each other.

3.2.1 PVC

PVC is a sturdy, yet very processable plastic. It can be sawn, cut or carved more easily than PP. But PVC often contains plasticizer, some of them toxic, making PVC a material to pay attention to. There is food-graded PVC tubings and pipes that is safe to use. PVC can be glued which is a big advantage in some applications.

3.2.2 PP

PP is a very steady and inert material, but it is difficult to glue due to its oily surface. Since it is very inert it is generally considered safe for use, safer than other plastics.

3.3 General concerns

Whenever introducing a new material to an aquaponic system, possible negative effects has to be considered.

The amount of the material is of course important; the compounds of a screw in a hose-clamp will probably not affect the system as much as possible content of heavy metals in the gravel of a media bed for example.

If food-graded material is available it will always be a preferred choice, but it will not always be possible to find at reasonable costs.

The purposed use of the material is important. Rubber lining for fish ponds might not be food-graded, but could be considered safe to use since it is commonly used in aquatic environments. Aquarium equipment will most likely be safe. One should be more concerned when using something not originally supposed to be put in an aquatic environment. Both the durability and the possible negative impact on the fishes or plants has to be considered.

4 Water flow chart and setup

During planning and designing of the demo, the risk of flooding and robustness/system simplicity were taken in consideration. It was decided that the most suitable system setup in our facility and size of

system was to put all the growing beds and the fish tank in parallel (as opposed to in series, where water usually is pumped to the fishes and then flows to the beds in series before it ends up in the sump). This allows for different flows in different beds as well as higher flexibility in placement of the system parts.

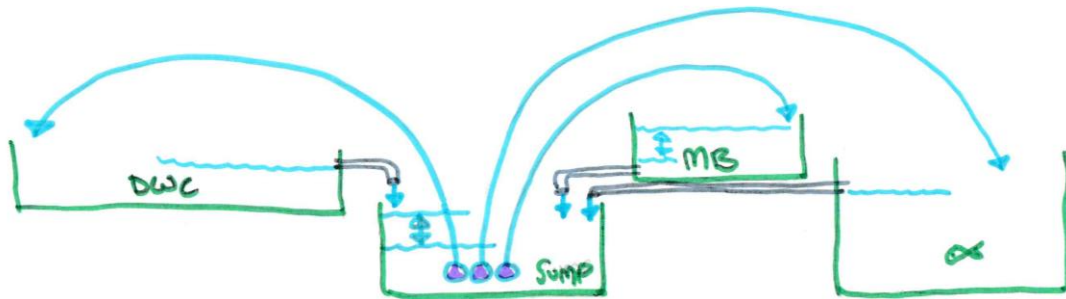

Figure 7. Schematic flow chart of the Demo

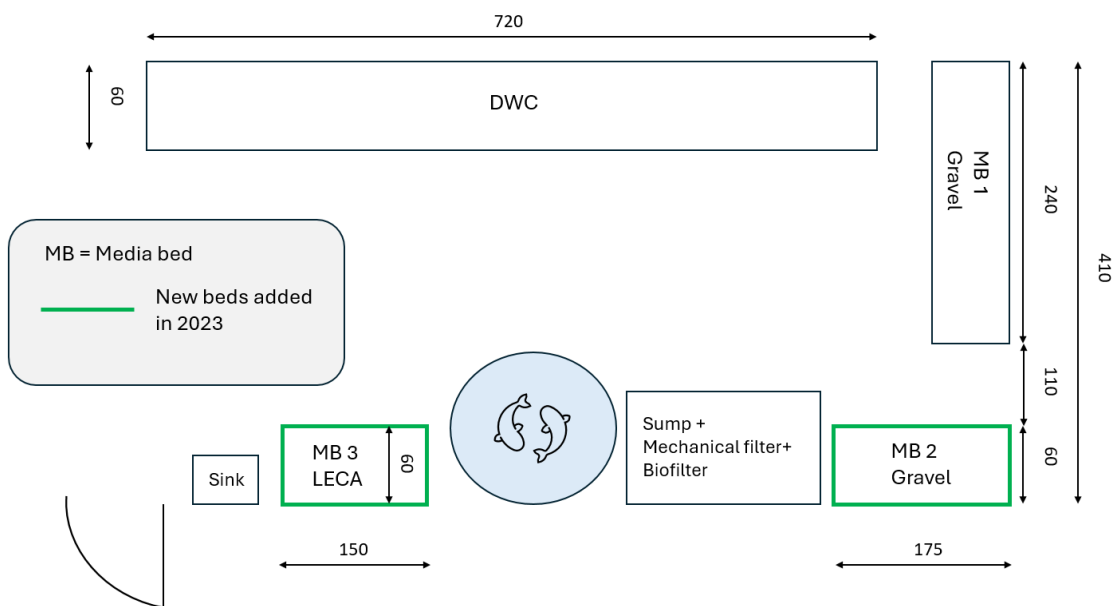

Figure 8. Scheme of the demo at Campus Roslagen, placement of the system parts.

The DWC with a water volume of 1 m^3 ($W \cdot H \cdot L = 0,6m \cdot 0,25m \cdot 7,2m$) has a pump with a rated flow of 2000 l/h running constantly. Adjacent from the water inlet there is an overflow outlet with 50 mm pipes back to the sump.



Figure 9. DWC outlet. The height of the water in the DWC is easily adjusted by changing the angle of the grey 50mm pipes. In this picture the DWC is not completely filled. During operation the water level in the DWC is just above the opening of the grey pipe, where the water overflows to the outlet and back to the sump.

The 3 Media beds in the demo have separate pumps controlled by timers set to run 30 min every 3 hours (Ebb/flood system described in chapter 5). The outlets of the Media beds flow by gravity in 50 mm pipes back to the sump.

The fish tank has separate pumps (2000 l/h + 1000 l/h) running constantly. The fishes would quickly suffer if (when) the pump fails. With two pumps running they will still have a flow in case of a pump failure, enough to keep the fishes from being harmed until the failed pump is replaced. There is also a backup system in place, in case of power outages, described in chapter 6. From the fish tank the water flows by gravity back to the sump, via a simple mechanical filter for sludge removal.

4.1 Reduction of flood risk

In systems with water circulating there is of course a risk of flooding. Leakages from containers could cause a slow but steady water loss and de-attached pipes or hoses could cause a flood in the facility of the system. Facilities should be chosen where a flooding will not cause damage to the building, but even so a flood will in most cases cause extensive disruptions on the system.

Means should be taken to avoid flooding as much as reasonable possible. Every system, setup, and facility are unique, and risk assessments have to be made regarding to the specific case, but a few rules and tips are more or less uniform.

- **Install water hoses above waterline.** If the outlet of a hose from a pump is installed below the waterline, the hose will act as a siphon when the pump is turned off (provided that the pump is placed below the outlet of the hose, which is usually the case). The system filled by the pump will empty through the hose until the water level sinks enough to let air into the hose.
- **Install air pumps above waterline.** Just like with water hoses, the air hose or tube from air pumps or compressors (for aeration of the water etc.) might act as a siphon if the air pump is turned off. This could be even more harmful since the air pump is not constructed for contact with water, resulting in equipment failure or even risk of electrocution. This risk is easily prevented by placing the air pump above the waterline.
- **Electrical equipment.** There are regulations regarding electrical installations (heights of installed plug sockets, residual current device etc.) that must be regarded, but also equipment that are not considered fixed installations must be taken into consideration. How would a flood effect the equipment? Could the equipment be placed differently to avoid or reduce risks? This has to be in the mindset whenever an electrical device is added to the system or facility.

5 Ebb/flood system design and construction

While in the DWC the water flow is constant, in the media bed it is possible to choose either to have a constant water flow or to use a ebb and flood system (also called flood and drain system), where the bed is alternatively submerged and drained with water which ensures a good aeration of the bed. This method is the one used for all the media beds in Campus Roslagen. A commonly used method of filling and emptying an ebb/flood system is using a bell siphon in a tank that has a constant water supply. The bell siphon is a construction where a bell that covers a high outlet pipe is creating a siphon when the water level rises enough to fill the bell. When the water exits through the outlet pipe inside the bell, a siphon with a suction is created. The outlet pipe has a dimension large enough to allow a flow higher than the constant supply to the tank.

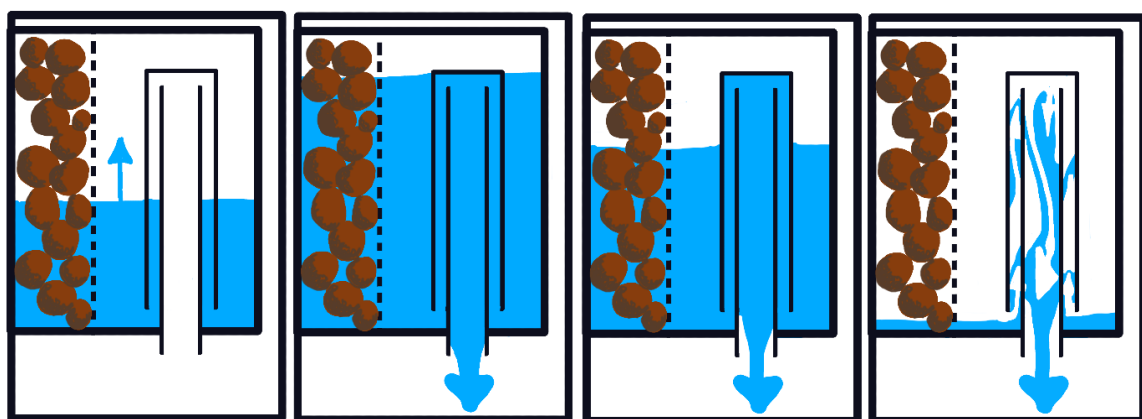

Fig. 15 – Representation of the bell siphon working principle.

As long as the water level outside the bell is higher than the bell opening at the bottom, the construction acts as a siphon and the water is sucked out of the tank. When the water level is low enough to allow air in to the bell, the siphon is disturbed and the suction stops, until the water level is high enough to start the cycle again.

In Campus Roslagen's demo we used another method to fill and drain the ebb and flow system. Instead of a constant water supply we set a timer to the pumps that pump the water from the sump tank to the media beds. The water is pumped for 30 minutes every three hours, filling the media beds to the desired maximum water level. The outlet from the media beds consists of a standing pipe with the height of the desired maximum water level, but the pipe also has a small hole at the height of the desired minimum water level. The lower hole in the pipe is not large enough to empty the tank when the pump is active; when the pumping cycle starts the water level rises until the top of the pipe is reached. The outlet pipe then keeps the maximum water level until the pumping cycle ends, and the water slowly exits the tank through the smaller hole until the minimum water level is reached.

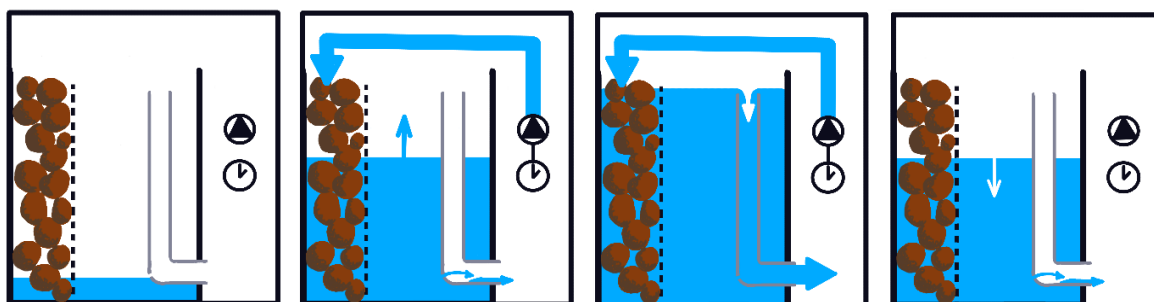

Fig. 16 – Representation of the ebb and flow working principle.

Media beds need to have three layers, from up to bottom: 1) the dry layer (max 5 cm), protects the roots from the light to prevent algae growth; 2) wet/dry layer (10-20 cm) where most of the biological activities happens thanks to the aeration provided by the ebb and flow system; 3) wet layer (max 5 cm), where mineralization happens, a process where solid particles are decomposed in smaller particles that are easier to be absorbed by the plants.

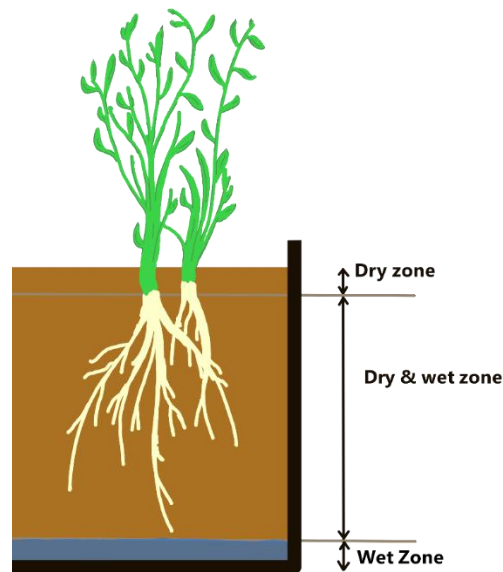

Fig. 17 – Stratification in a media bedd

The construction needs to be done in such a way to guarantee the depth of these three layers, i.e. the position of the inlet and outlet of the siphon will determine the start and end of the wet/dry zone.

6 Back-up system

A back-up system is crucial when unexpected faults occur. Before designing a back-up system, efforts has to be put in to a risk assesment in order to back up the most important components that are most likely to fault.

For example, in Campus Roslagen demo the most fragile system, sensitive to technical failiure, is the fish tank. If the pump that pumps water to the fish tank faults, the fishes will be harmed by decreasing oxygen and rising levels of toxins in the water. One obvious risk for this to happen is a power outage, but just as likely the pump itself might (or *will*, sooner or later) stop working. By installing a second, smaller pump besides the main one the concequense of a pump failure was easily reduced from crucial to slightly problematic.

As for a power outage at Campus Roslagen demo site, the main issue is to keep the fishes healthy. The growth rate of the plants will of course be reduced due to lack of lighting, the plants in the DWC might be disturbed by the lack of water flow and the room temperature will slowly drop, but the hydroponic unit will not be permanetly damaged by a power outage.

There is of course a wide range of back-up systems in capacity and cost. The system designed for Campus Roslagen demo site is a very small and cheap one, but fairly fail-safe and capable of running a water pump and an air pump for several days.

The system consists of a set of 12V acid lead batteries (deep cycle batteries usually used in of-grid solar systems or leisure boats), a battery charger for keeping them in shape, two voltage converters (12VDC -> 230VAC and 230VAC -> 12VDC) and a relay.

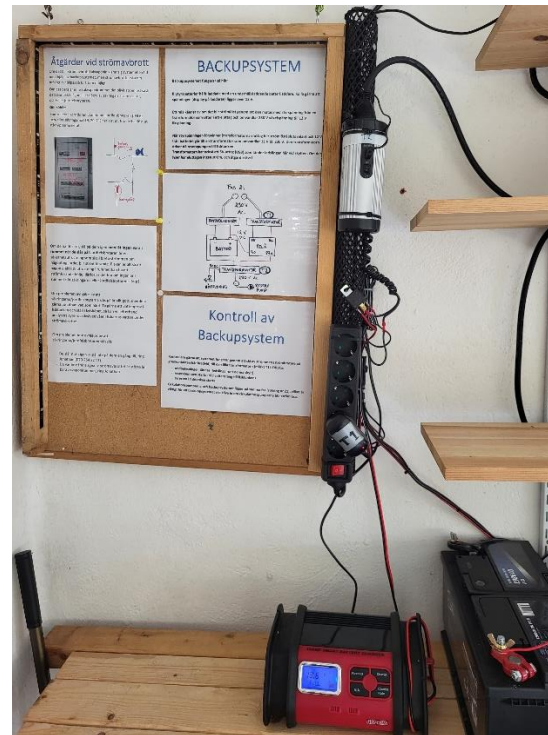
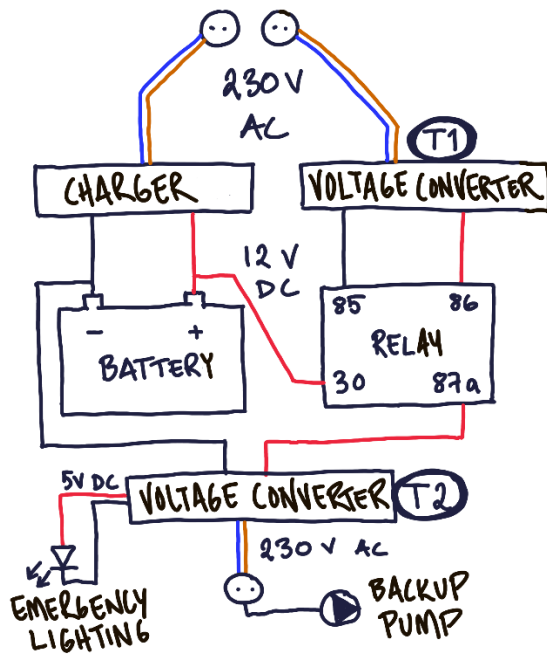

Fig. 18 – Schematization of the back-up system