

# FISH IN AQUAPONICS – SELECTION, REQUIREMENTS AND LIMITATIONS

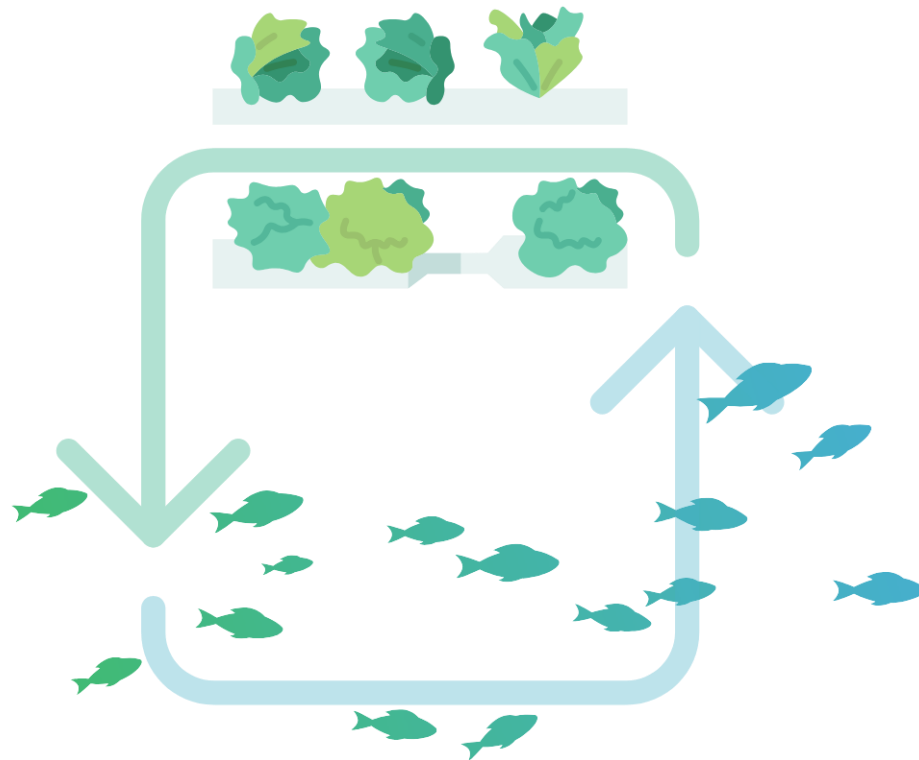

## Table of Contents

Abstract .....	3
1. Introduction .....	4
1.1. TransFarm project .....	4
1.2. Fish in aquaponics.....	5
2. Water quality requirements for fish.....	6
2.1. Temperature.....	6
2.2. Oxygen.....	6
2.3. pH.....	9
2.4. Other requirements.....	10
3. Aquaculture in aquaponics.....	12
3.1. Selection and types of fish tanks.....	12
3.2. Removal of sludge, mechanical filters .....	17
3.3. Disinfection and aeration of water.....	19
4. Selection of the fish species .....	24
4.1. Salmonoids.....	25
4.2. Percidae (perch and pikeperch) .....	27
4.3. Siberian Sturgeon ( <i>Acipenser baeri</i> ).....	29
4.4. African Catfish ( <i>Catfish gariepinus</i> ) .....	31
4.5. Tilapia ( <i>Oreochromis sp.</i> ).....	32
4.6. Carp ( <i>Cyprinidae spp.</i> ) .....	33
4.7. Crustaceans.....	34
5. Fish feed/nutrition .....	36
5.1. Fish feed types .....	36
5.2. Feed composition .....	41
5.3. Feeding rates.....	45
6. Fish health and welfare .....	46
6.1. Pests and diseases.....	46
6.2. Stocking density .....	50
References.....	53

## Abstract

Aquaponics is an agricultural method that integrates the cultivation of soilless plants (hydroponics) with the raising of fish (aquaculture) in a closed-loop system. Fish waste serves as a source of nutrients for the plants, which in turn purify the water for the fish. This approach mitigates the environmental impact and provides a solution to the environmental and social challenges faced by the food industry. The selection of suitable fish species is essential and is contingent upon factors such as market demand and water temperature. Trout, catfish, and tilapia are among the most frequently selected species. Each species has distinct requirements for environmental parameters, nutrition rates, and stocking density. For aquaponics to be successful, it is essential to manage water quality, as parameters such as temperature, oxygen, pH, and water velocity have a substantial impact on both fish and plants. The biofilter, which converts fish excrement into plant nutrients, and the survival of fish are contingent upon the maintenance of appropriate oxygen levels. Aeration methods guarantee sufficient oxygen levels, while disinfection methods, including UV sterilisation and ozonation, aid in pathogen control. The health of fish is of the utmost importance, and diseases such as Ich, flukes, and columnaris can proliferate rapidly in enclosed systems. To prevent diseases, it is necessary to maintain optimal water quality, quarantine new fish, and provide a balanced diet. To prevent health risks, the stocking density must be able to sustain water quality while balancing fish biomass for nutrient production. The optimal composition of fish feed should consist of protein, carbohydrates, lipids, vitamins, and minerals to promote growth. Aquaponics practitioners can establish a sustainable and productive ecosystem that produces high-quality fish and fresh produce by balancing stocking density, feeding rates, water quality, and fish health management.

**Keywords:** Fish, requirements, species, TransFarm, Interreg, Aquaponics, resilience, sustainability

The information included in this report is a compilation of various articles and books of which the references can be found in the report section “References”.

The preparation of this report has been supported by Interreg Central Baltic Region project CB0100007 “TRANSborder cooperation for circular soil-less FARMing systems - TransFarm”.

## 1. Introduction

### 1.1. TransFarm project

There are several environmental and social challenges that the food sector must face: Agriculture is a sector particularly affected by climate change, our seas are overfished, and the world population is estimated to continue growing, being about 9.7<sup>1</sup> billion people by 2050. Countries in the Baltic Sea Region are strongly dependent on food import, especially for vegetables, fruit and fish; in recent years the pandemics and the war in Ukraine have exposed the need for more self-sufficient food systems. Moreover, agriculture and aquaculture are among the main contributors to the eutrophication of the Baltic Sea. (UL)

To answer these challenges TransFarm project wants to bring food production closer to consumers by promoting soil-less farming methods that can be implemented even indoors and allow it to grow all year round. Examples of these methods are hydroponics, where plants are grown in water, and aquaponics, which combines hydroponics with aquaculture.

Aquaponics is a circular, closed-loop system, where water from the fish culture is used to grow plants. The fish waste within the water is microbiologically transformed by a biofilter, absorbed by plants and then cleaner water returned to the fish. The system has a completely circular water flow allowing nutrient reuse without emissions of nutrients in the environment. Since the fish, plants and microorganisms in an aquaponics system function in close symbiotic relationships, antibiotics or pesticides are not used, which in turn provides cleaner, healthier produce.

TransFarm will demonstrate aquaponics in Sweden, Estonia and Latvia as well as test alternative water sources such as rainwater and reclaimed greywater: Partners from these countries will build demonstration facilities with different characteristics and aims. The experiences exchanged from the different demos will contribute to knowledge co-creation and the facilities will be the opportunity to inspire and educate future aquaponics farmers. The knowledge gathered from the construction and monitoring of the demos will result in education material available for all the actors interested in aquaponics.

The project will also investigate business models, run activities to inform consumers about the quality of the aquaponics produced, educate entrepreneurs who want to start an aquaponics system as well as inform civil servants and policy makers about the reduced environmental impact of circular soil-less farming methods.

---

TransFarm project duration is three years (2023-2026), and it is coordinated by **Turku School of Economics** at the University of Turku (Turku, Finland). Project partners are the **Estonian University of Life Sciences** (Tartu, Estonia), **University of Latvia** (Riga, Latvia), **Norrhälje Vatten och Avfall (Campus Roslagen)** and **Coompanion Roslagen & Norrort** (Norrhälje, Sweden).

TransFarm project is funded by the EU's Interreg Central Baltic program, the total budget of the project is 1.87 million euros, EU financing covers 1.5 million euros.

---

<sup>1</sup> UN DESA publications – World population prospects 2022

## 1.2. Fish in aquaponics

Aquaponics is a soil-less agricultural farming method that combines aquaculture (the cultivation of fish) and hydroponics (the cultivation of plants). In an aquaponics system arguably the most important part is the fish – they are the organisms that provide the whole system with nutrients – they are at the heart of this symbiotic ecosystem. Fish through their metabolism of the fish feed contribute to the nutrient cycling balancing of the system. Fish waste is not regarded as refuse in aquaponics; rather, it is regarded as a valuable resource. Ammonia, a nitrogen-rich compound, is released into the water by fish as they metabolise food. The ammonia is converted to nitrites and nitrates by beneficial microorganisms in the biofilter of the system. These chemicals are readily absorbed by plants as essential nutrients. This natural process of nutrient cycling eliminates the necessity for synthetic fertilisers, thereby reducing the environmental impact and establishing a closed-loop system in which refuse is converted into a valuable input (Figure 1).

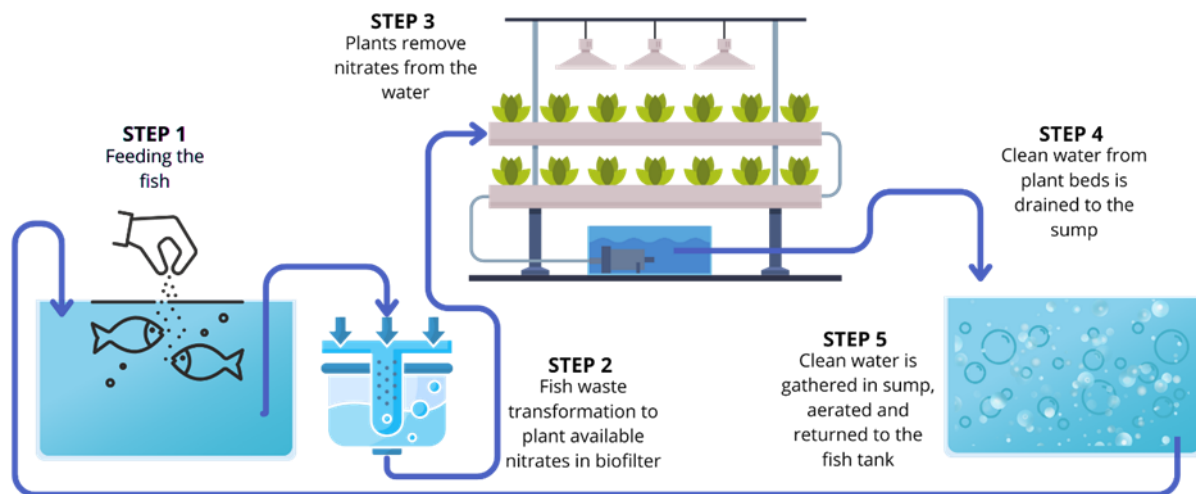

Figure 1. Generalised schematic of an aquaponics system with nutrient film plant growth channels.

This report focuses on the different aspects of the fish within the aquaponics system. Firstly, the water quality requirements that are specific to the fish are discussed. Further, the different options that can be used as the fish's living space – the fishtanks – are described with their pros and cons. Since fish feed is the primary and only input of nutrients into the system careful consideration of the food you are giving the fish must be made. The most important groups of nutrients have been described in detail. Possible fish species with the respective growth conditions have been summarised. Since aquaponics is usually a limited-size operation, and the stocking density of the fish is kept at the maximum, depending on the species, it is important to be aware of the pests and diseases that can negatively impact the functioning of an aquaponic system.

A successful aquaponics system is not merely the result of the presence of fish; it is also the propelling force behind it. They are the driving force behind nutrient cycling, supplying the fundamental building blocks necessary for plant growth. A thriving and sustainable aquaponics ecosystem necessitates the selection of suitable fish species, the optimisation of their environment, and the management of their health.

This report is part of a series of training materials prepared by the Interreg Central Baltic programme project TransFarm (TRANSborder cooperation for circular soil-less FARMing systems) (No. CB0100007). This report is a deliverable (D3.4.1) of Work-package 3, Activity 3.4 and should be used together with the deliverables D.3.3.1 (Training materials on plants in aquaponics) and D3.2.1(Training materials on water quality in aquaponics).

## TransFarm

### 2. Water quality requirements for fish

#### 2.1. Temperature

The ecosystem within an aquaponics system is significantly influenced by temperature. Certain plants flourish in chilly environments, maintaining their health, strength, and rapid growth. In the interim, fish in the system must satisfy specific criteria, as their nutrient contributions are crucial for the growth of plants. Aquaponics producers must be prepared to measure the system in degree-days, a unit that accounts for the accumulation of temperature over time.

Initially, the biofilter must be activated to provide plants with the requisite nitrates and carbon dioxide. A convenient method is to initially set the biofilter at a temperature of 20-22°C, and subsequently decrease it as nitrates begin to accumulate in the system. Finally, it is imperative to incorporate fish into the system at this juncture to ensure that nutrients accumulate at a rate that is advantageous to plant growth.

There is an alternative approach: the introduction of fish from the outset. Nevertheless, this method necessitates monitoring of ammonia ( $\text{NH}_3/\text{NH}_4$ ) levels and the nitrification processes to prevent toxicity before it can reach detrimental levels. Fresh water can be introduced to dilute and reduce toxic concentrations to address this issue. In Nordic climates, freshwater additives are also beneficial for cooling the system during hot summers; however, they may result in excessive cooling during colder periods. All these modifications affect the aquaponics system's primary components: the biofilter, the fish tank, and the conservatory for plants. It is imperative to monitor temperature, as it has an impact on all biological processes within the system. A standard thermometer should be maintained as a fallback, despite the value of a digital monitoring system. Faulty readings can jeopardise the system's health, necessitating consistent calibration of digital sensors to guarantee accuracy.

It is uncommon to find a location that is stable and maintains temperatures that are optimal for both fish and vegetation. Air and water temperatures are frequently influenced by seasonal fluctuations, necessitating optimisation of available sites. There are numerous methods for regulating temperature, for example, air-Based Temperature Control. In certain configurations, the central climate control system incorporates an air-air heat pump or an air-water heat pump to modulate air temperature. Humidity control is feasible with this configuration. Water-based temperature control is an additional alternative that heats the water directly. However, this method can result in an increase in air humidity of up to 85%, which can cause condensation on surfaces. While some plants may benefit from this increased humidity, it can also promote the growth of mould and algae, particularly when artificial illumination is employed. To prevent moisture accumulation, electrical systems must be adequately insulated and subjected to routine inspections.

In Nordic climates, certain farms utilise geothermal energy or adjacent water sources for heating, which frequently necessitates the use of heat exchangers or floor heating. This method may lead to a reduction in humidity levels (25-35%), which may require the installation of additional humidifiers. In cooler climates, a temperature pairing of 16-17°C is appropriate for aquaponics, which can sustain rainbow trout and crops such as spinach and lettuce. In milder climates, a system maintained at 22-26°C is effective when combined with catfish and crops such as basil and tomatoes. Humidity should be monitored, and foggers may be employed as required.

#### 2.2. Oxygen

In aquaponics and other aquatic agricultural systems, oxygen is essential for the survival of inhabitants such as fish, crustaceans, mussels, snails, and turtles. Even though fish inhabit water ( $\text{H}_2\text{O}$ ), they are

### TransFarm

unable to directly utilise the oxygen that is bonded to hydrogen molecules. Fish, like humans, require unrestricted, dissolved oxygen (DO) to breathe, which must be uniformly distributed throughout the water. Temperature and oxygen levels are inextricably linked in aquaculture. The inverse relationship between temperature and dissolved oxygen capacity results in a decrease in dissolved oxygen as the temperature of the water increases. The amount of oxygen that the water can naturally contain at any given moment is essentially determined by temperature. Oxygen is essential for all components of aquaponics systems, including fish, biofilters, and vegetation. It is typically quantified in terms of concentration (ppm or mg/L) and saturation (%). To preserve a healthy environment, aquaponics producers must monitor and comprehend a variety of oxygen-dependent processes, such as biochemical oxygen demand (BOD), nitrification, photosynthesis, and respiration, which all affect oxygen levels.

Dissolved oxygen is consumed by system inhabitants, such as fish and decomposing bacteria. This oxygen demand, referred to as biological oxygen demand (BOD), is crucial to monitor, particularly because the oxygen levels are diminished by the microorganisms in biofilters and the fish in recirculated water. Regular cleansing and maintenance are essential to prevent the accumulation of excess biofilm, which is the layer of bacteria that develops in biofilters. This prevents the biofilm from spreading over plant roots and tank walls. Biofilm can disrupt water flow and reduce oxygen availability without this maintenance.

The oxygen content of water can fluctuate rapidly, sometimes within a matter of minutes, which can result in potentially lethal conditions for fish. Farmers are required to monitor fish for behavioural indicators, as low oxygen levels are not readily apparent. Fish swimming at the surface of the water and panting as if "biting" at the air are early indicators of low oxygen. This behaviour is frequently observed when oxygen levels decrease to 4-3 ppm. Fish may display signs of distress, such as feverishly attempting to escape, jumping out of the tank, or lying quietly at the bottom or near water inlets and outlets, if levels continue to decline to 1-3 ppm. Prolonged periods of low oxygen levels can impede the passage of water and result in hazardous overflows. Certain fish species, such as African catfish, can adjust to reduced oxygen levels by ascending to the surface to breathe, while others, like gars, may begin to utilise atmospheric oxygen. Nevertheless, these adaptations are only able to occur after a protracted period of exposure to low or sub-lethal DO levels. These conditions may result in the death of numerous aquatic organisms, as they are unable to adapt.

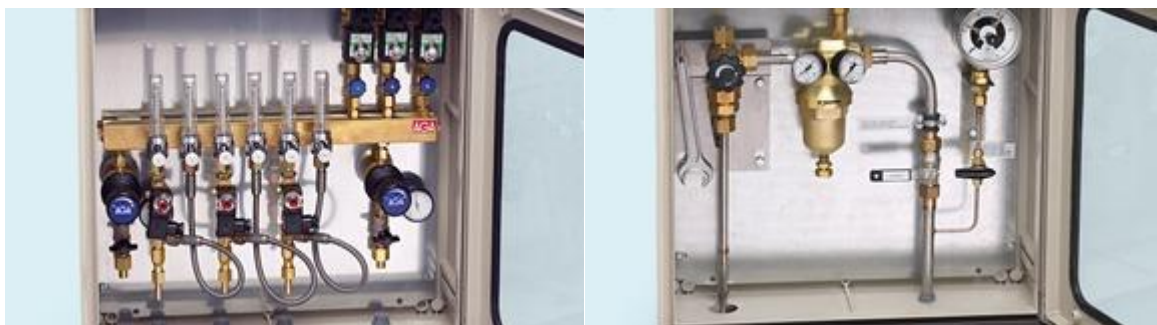

Figure 2. Linde Gas O<sub>2</sub> flow or dosing box and emergency O<sub>2</sub> box.

It is advisable to temporarily cease feeding the fish and, if feasible, introduce fresh water to slightly calm the system when confronted with low oxygen levels. The oxygen demand is reduced by the fact that fish are less active, and cooler water more effectively retains dissolved oxygen. To ensure the health and economic productivity of fish, it is recommended that dissolved oxygen levels be

TransFarm

maintained at a level between 7.5 and 9.5 ppm (Figure 2). This will facilitate the efficient metabolism of protein and promote the growth of the fish. In aquaponics systems, the decomposition of organic matter by microorganisms in the biofilter necessitates dissolved oxygen (DO), which in turn generates essential nutrients for plants. Bacteria utilise an increased amount of DO to sustain the decomposition process when there is an accumulation of excess organic matter. Consequently, it is imperative to monitor and regulate the accumulation of biofilm, sludge, and detritus. If the recirculated system is not filtered to remove sludge or suspended particles, the oxygen demand may rise, potentially resulting in oxygen shortages. The oxygen supply in aquaponics is managed through three systems: biological demand, nutrition demand, and emergency supply, to maintain optimal oxygen levels. Biological demand - relatively constant and increases in proportion to the total biomass in the system. It symbolises the oxygen necessary for the daily respiration and metabolism of bacteria, vegetation, and fish. Feeding demand - the metabolic activity of fish elevates temporarily during and immediately following feeding, resulting in a temporary increase in oxygen demand. To preserve equilibrium, oxygen sensors in each fish tank in large-scale operations monitor levels and notify the primary control system, which temporarily opens oxygen supply valves. Emergency supply - backup oxygen is supplied during equipment or power failures by emergency systems. Backup generators are indispensable for large plantations to guarantee an uninterrupted oxygen supply. Even small-scale and hobbyist operations can benefit from a dependable secondary power source to safeguard fish during unforeseen outages.

Depending on the scale of the system and the oxygen requirements, there are a variety of methods available to introduce oxygen into aquaponics systems. A rudimentary aeration pump with aeration tubing or ceramic stones typically provides sufficient oxygen in small-scale systems. Medium-sized systems with higher oxygen demand frequently employ fine perforated diffusers to improve aeration, in addition to an oxygen generator or pressurised oxygen canisters to ensure a consistent supply. Large-scale systems necessitate sophisticated oxygenation configurations, which can be achieved using liquid oxygen pressure systems or oxygen generators. Oxygen generators provide on-demand oxygen production, while pressurised systems provide high-capacity, conserved oxygen for immediate use. Each method has its advantages. Nevertheless, liquid oxygen systems typically necessitate more intricate and secure handling.



Figure 3. Atlas Scientific monitoring system and Handy Oxyguard O<sub>2</sub> sensor.

It is essential to monitor oxygen levels to ensure the efficacy and health of the system (Figure 3). The daily maintenance of oxygen probes is necessary to prevent the accumulation of biofilm, particularly in warm-water systems, where both manual and stationary probes are employed for monitoring. For example, anode-cathode probes may necessitate more frequent cleansing than optical probes due to the potential impact of biofilm on their readings. It is also imperative to conduct regular calibration



per the manufacturer's specifications. Prompt servicing of defective probes is necessary, which may involve the replacement of membranes, the refilling of probe liquids, or the cleansing of the probe's internal components. Natural oxygen sources can be utilised by aquaponics systems to minimise the necessity for oxygen supplementation. The natural increase in DO levels is facilitated by the production of oxygen by algae, seaweed, and other aquatic plants as a byproduct of photosynthesis. Temperature control is essential for optimising this process, as it impacts the rate of plant respiration and oxygen production. Maintaining the water at an appropriate temperature can improve the efficiency of photosynthesis, thereby ensuring a consistent oxygen supply for the entire system. Maintain dissolved oxygen levels between 7.5 and 9.5 ppm to promote the growth of healthy fish and the efficient metabolism of protein. This range enhances the health and development of fish, thereby facilitating the production of aquaponics that is economically sustainable.

### 2.3. pH

The pH scale is a logarithmic measure that is employed to describe the acidity or basicity of aqueous solutions. Acidic solutions have lower pH values due to the presence of higher concentrations of hydrogen ions (H<sup>+</sup>), whereas basic or alkaline solutions have higher pH values due to the presence of fewer hydrogen ions. Each pH unit represents a tenfold difference in hydrogen ion concentration, as the scale operates on a base-10 logarithmic system. Solutions with a pH below 7 are classified as acidic at a standard temperature of 25 °C, while those with a pH above 7 are classified as basic (Figure 4).

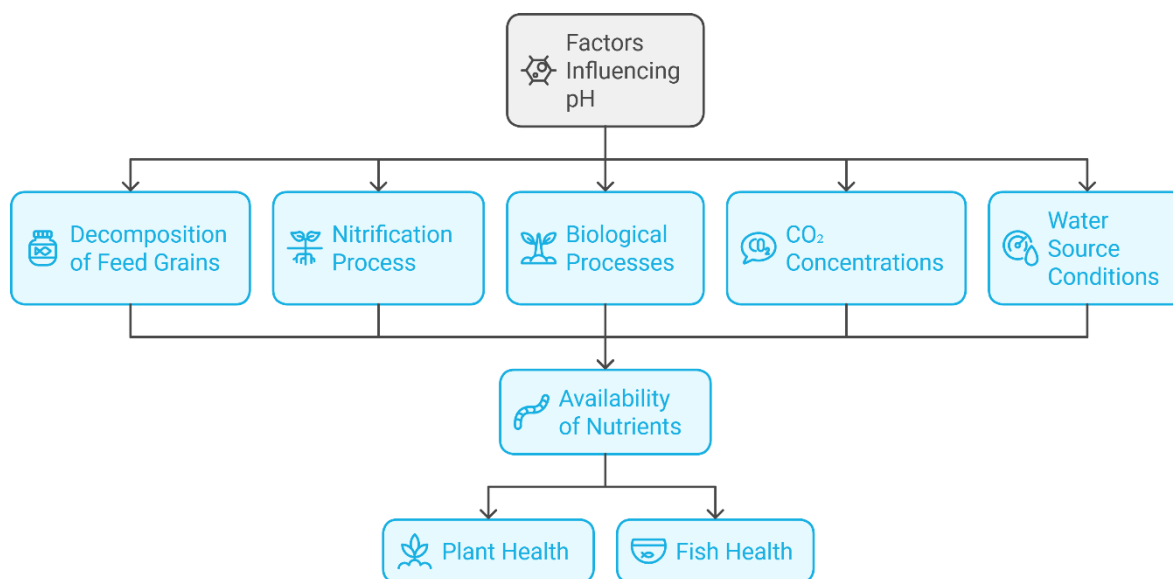

Figure 4. Summary of factors influencing the pH of an aquaponics system.

pH is a critical parameter in aquaponics, as it influences the integrity of the system, microbial activity, and the availability of nutrients. The solubility of essential nutrients is directly influenced by the pH level, which in turn affects the availability of these nutrients for plant absorption. Consequently, plant health and growth are influenced. Additionally, pH is a critical factor in determining the toxicity of specific compounds, including ammonia, which becomes more hazardous to aquatic organisms as pH levels rise. For these reasons, it is essential to maintain a stable pH to guarantee a healthy and balanced aquaponics system. pH is influenced by a variety of factors in aquaponics systems. For instance, fluctuations may result from the decomposition of feed grains in the tank. As these pellets decompose, they release ammonia, which can gradually modify the pH. The nitrification process converts ammonia, a nutrient source for beneficial microbes in the biofilter, to produce additional acidity in the water. This acidity has the potential to increase nitrites, which, if left unchecked, could result in toxicity surges in

TransFarm

the system. Proper feeding practices, which are ideally suited to the fish species and size, can assist in mitigating these effects, as the feed can fluctuate between 0.3% and 6% of the fish biomass in an aquarium.

The pH levels are further influenced by biological processes, as organic material and ammonia are introduced to the water by refuse from feed, fish faeces, or even decomposing fish. The growth of beneficial bacterial colonies is facilitated by these substances, which initially elevate the pH and subsequently decrease it through ongoing decomposition. Nitrification, a process that steadily increases the acidity of water, generates nitrites and nitrates. Furthermore, the pH of the environment is influenced by the absorption of nutrients by plants and the subsequent release of ions, including nitrates and carbonates. The pH can be either elevated or decreased depending on the specific ions involved.

Carbon dioxide concentrations are also a substantial factor in pH stability. High concentrations of CO<sub>2</sub> in water result in the formation of carbonic acid, which decreases the pH. Conversely, lesser CO<sub>2</sub> levels can reduce acidity. Finally, the pH of the water is significantly influenced by the condition of the water source, as the buffering capacity of freshwater is influenced by its pH and hardness. A greater buffering capacity necessitates the use of larger quantities of pH-adjusting compounds, such as hydrochloric acid (HCl) to increase acidity or sodium hydroxide (NaOH) and calcium hydroxide (slaked lime, Ca(OH)<sub>2</sub>) to raise pH. Inconsistent pH levels can impede the development of plants and decrease the yield of crops. Nutrient absorption in plants is highly sensitive to pH, and when it deviates from an optimal range, essential nutrients become less available, compromising plant health and growth. Impaired physiological processes, including photosynthesis, can also lead to nutrient imbalances and a reduction in the plant's ability to withstand stressors. Although manual adjustments can be made as required for pH monitoring, automated, stationary systems offer greater stability and efficiency by facilitating real-time adjustments.

Prolonged exposure to pH levels that are not appropriate for fish can result in stress, weakened immunity, and an increased susceptibility to disease. Physiological functions may be disrupted, appetites may be reduced, growth may be slowed, and fish may be more susceptible to fluctuations in water chemistry when they are exposed to pH instability. To mitigate detrimental impacts on fish health, pH fluctuations should not surpass 0.5 units within 24 hours. Consistent monitoring and precise adjustments are essential for maintaining a balanced aquaponics environment, although manual pH adjustments may necessitate slightly higher quantities of adjusting agents to ensure stability.

2.4. Other requirements

*Water flow and circulation*

The central component of a recirculated aquaculture system is the pump. Frequency modulators are advised for pumps, contingent upon their specifications and capabilities. Pumps are energy-intensive; therefore, it is more energy-efficient to utilise a single pump to circulate the entire water supply. To ensure that the water is constantly flowing, it is advisable to install a secondary pump in the same location and operate both pumps on a regular schedule to prevent the accumulation of sediments or the clogging of the pump housing. It is feasible that

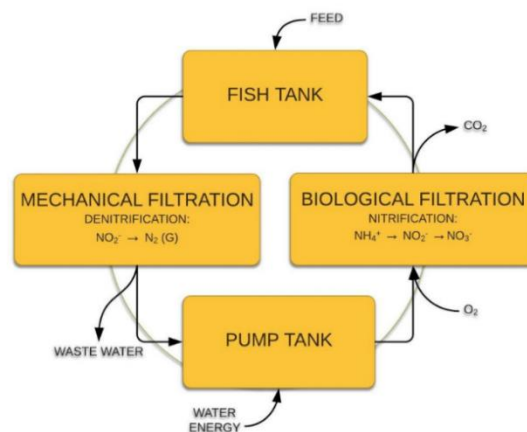

Figure 5. The inputs and outputs of an aquaponics system.

## TransFarm

one of the pumps will require replacement or removal from the system for maintenance during operation. For this purpose, implement the pump with two valves, one in front of the inlet and the other closing the outlet. When designing the system, it is important to consider the use of modest lifting heights to reduce operating expenses. The water is only lifted once during each circulation. The pump is primarily positioned in front of the biofilter inlet, as well as in front of oxidising units and fish tanks, to ensure that the system is pressurised appropriately (Figure 5).

The frequency modulator also assists in the induction of water velocity. It is necessary because certain fish species require a higher water rate to maintain an environment that is suitable for them. Occasionally, an increased flow rate can have additional positive effects, such as the reduction of cannibalism and the reduction of detritus on the tank floor.

### *Daylight schedule*

In a controlled, confined recirculated aquaculture system, the health and growth of the fish and plants are both dependent on the management of light exposure. The light arrangements for fish are customised to accommodate the unique requirements of each species. For instance, sturgeon flourish in a 16-hour daylight and 8-hour night cycle, which replicates a natural environment and optimises their growth. Nevertheless, perch species necessitate continuous dim illumination (24 hours a day) to prevent stress, as any change in light can disrupt their feeding and resting patterns. To prevent them from being startled, salmon species necessitate gradual transitions between day and night, as they are more susceptible to abrupt light changes. A sudden change can induce stress responses, such as a "wave" effect, in which groups of fish may suddenly spring from the water, potentially causing themselves harm. In contrast, catfish are nocturnal and are most effectively raised in conditions of near-total darkness, with only the bare minimum of light required for staff operations to prevent them from disrupting their natural behaviours (Figure 6).

The function of light in aquaponics systems is not limited to the fish; it also affects the plants, which need light to facilitate photosynthesis. Photosynthesis is the process by which plants convert light energy into chemical energy, thereby generating the oxygen that fish require and removing nutrients from the water that would otherwise accumulate as detritus. In a shared aquaponics environment, the illumination requirements of the fish may conflict with the plants' requirements for optimal growth, which typically require 12-16 hours of light per day. To effectively manage light exposure, farmers may need to implement shading strategies for the fish tanks or even section-off areas of the facility. This will help to balance these requirements. Shading fish aquariums or establishing physical barriers between plants and fish can provide the necessary darkness for fish, while also ensuring that plants receive sufficient light.

The quality and style of light employed are additional factors to consider when designing light schedules in aquaponics. It is frequently necessary to use artificial lighting in indoor systems to supplement or supplant natural sunlight. LED grow lamps are frequently employed for their energy efficiency, flexibility in adjusting colour spectra to accommodate the photosynthetic requirements of plants, and minimal heat emission. For instance, blue and red wavelengths are particularly advantageous for plant growth, as they stimulate photosynthetic activity. Nevertheless, the necessity of establishing lighting schedules and intensity levels is further emphasised by the fact that protracted exposure to these specific wavelengths may not be suitable for certain fish species.

TransFarm

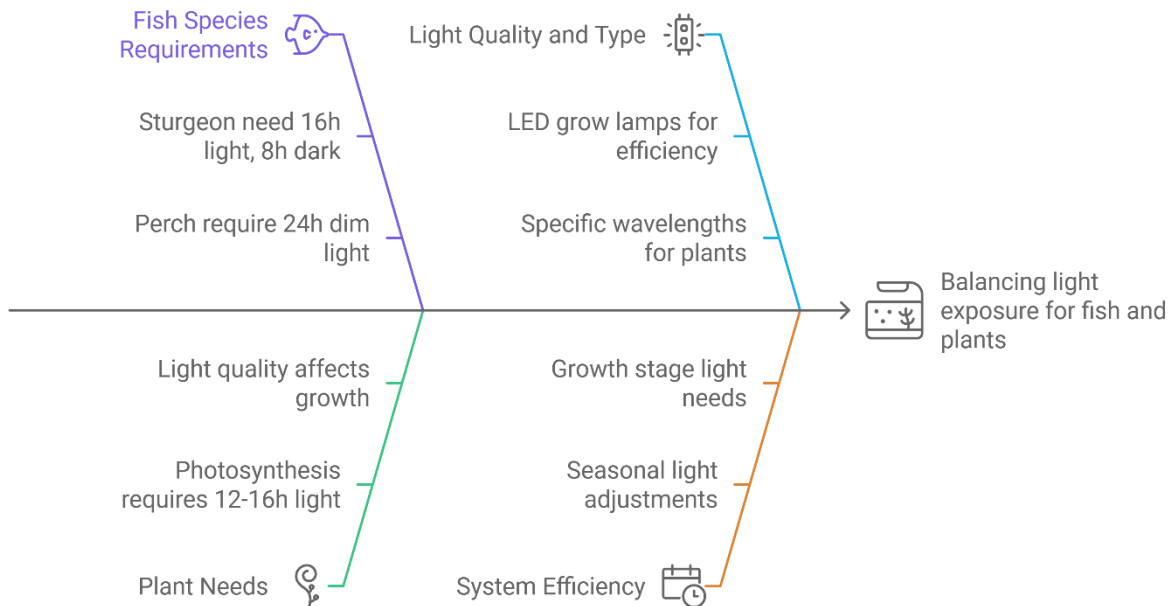

Figure 6. Lightning conditions and aspects influencing the light-cycling of an aquaponics system.

System efficiency can be considerably improved by monitoring light exposure and adjusting it seasonally or in accordance with the growth stages of plants and fish. Initially, young plants may necessitate more light to establish robust root systems, whereas mature plants can tolerate a minor reduction in light intensity. In the same way, the intensity of light required by fish may fluctuate based on their growth stages and environmental factors, including water temperature and feeding schedules. Aquaponics producers can optimise productivity and guarantee the well-being of both organisms within the system by establishing an environment that caters to the distinct requirements of both fish and plants through the observation and adjustment of light schedules.

### 3. Aquaculture in aquaponics

#### 3.1. Selection and types of fish tanks

The fish tank is an essential component of aquaponics since it serves as a home for the fish, whose excrement supplies the plants with the nutrients they need to thrive. The efficiency of the system, the health of the fish, and the overall functioning are all substantially impacted by the tank that is selected. Applications ranging from backyard hobby systems to large-scale commercial operations can be accommodated by a variety of tanks, each of which is designed to meet specific needs. When it comes to making educated judgements about which kinds of fish to grow and how to maximise the performance of the system, having a thorough understanding of the advantages and disadvantages of each type of tank comes in handy (Figure 7).

TransFarm

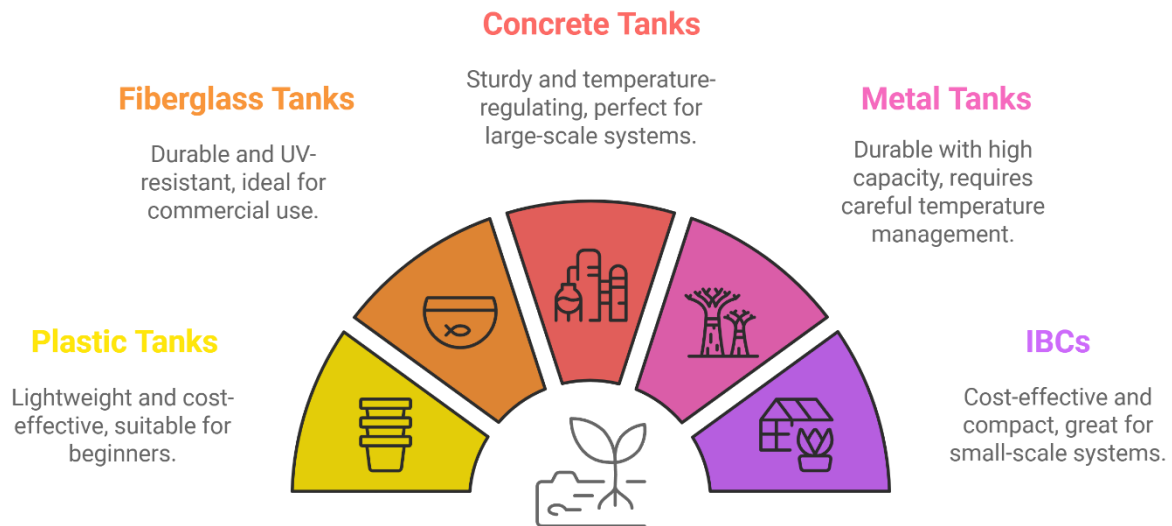

Figure 7. Types of containers and tanks used for fish in aquaponics system.

**Plastic or Polyethylene Tanks**

When it comes to aquaponics systems, plastic or polyethylene tanks are among the most common solutions, particularly in smaller to medium-scale setups (Figure 8). These tanks are recommended since they are lightweight, durable, and cost-effective. They are constructed from high-density polyethylene (HDPE) or other plastics that are suitable for use with food. These tanks are available in a variety of shapes, including round, rectangular, and oval designs. They are simple to handle, transport, and install, which makes them an excellent option for aquaponics enthusiasts who are just starting. They are made of a non-corrosive material, which ensures that they do not contaminate the water. Additionally, their excellent thermal insulation helps in keeping consistent water temperatures, which is critically important for the health of fish. Nevertheless, plastic tanks are susceptible to scratches, which, with time, may result in the formation of places in which bacteria can develop. In addition, they do not have the same durability as other materials, such as concrete or fibreglass, particularly when they are subjected to radiation from ultraviolet light for a lengthy period. Considering this, users are strongly encouraged to take into consideration the provision of some type of protection from direct sunlight, particularly in outdoor settings. Plastic tanks are an excellent choice for housing fish species such as tilapia, catfish, and trout because these fish are robust and can adapt to a wide range of water environmental conditions.



Figure 8. Plastic tanks and containers used for fish cultivation in an aquaponics system.

## Fiberglass Tanks

Because of its outstanding robustness and lifespan, fibreglass tanks are a popular choice for both commercial and high-end aquaponics systems (Figure 9). This is because fibreglass tanks are known for their reputation. Fibreglass-reinforced plastic, which is used in the construction of these tanks, strikes a compromise between being lightweight and extremely sturdy. Fibreglass tanks can be fabricated to the customer's specifications in a wide range of forms and sizes, which enables them to accommodate a variety of system configurations and fish stocking volumes. Because of their smooth surface, they are simple to clean, which reduces the probability of trash building or biofilm accumulation, both of which have the potential to impact the quality of the water. This means that fibreglass tanks are resistant to damage from ultraviolet light and corrosion, which means that they can be used both indoors and outside without deteriorating over time. This is another key advantage of fibreglass tanks. However, despite these benefits, fibreglass tanks are typically more expensive than plastic or IBC tanks, which might be a disadvantage for establishments that are concerned about their financial situation. In addition, although it is long-lasting, fibreglass can get chipped or cracked if it is handled improperly or subjected to strong impacts; therefore, it is necessary to exercise caution when moving or cleaning it. Several fish species are regularly farmed in fibreglass tanks. These fish species include tilapia, perch, and barramundi, all of which thrive in conditions that have consistent water quality and stable temperatures.



Figure 9. Fiberglass fish tanks are used for fish cultivation in aquaponic systems.

## Concrete Tanks

When it comes to large-scale, commercial aquaponics systems, concrete tanks are an indispensable component. This is especially true in locations that are warm or tropical, where the capacity of these tanks to regulate temperature becomes an advantage (Figure 10). The use of reinforced concrete in the construction of these tanks gives them an exceptionally tough and long-lasting construction that can often survive for decades if they are properly maintained. When compared to other types of tanks, concrete tanks are often custom-built to meet the requirements of the system. This allows for larger water volumes and higher fish stocking densities than other types of tanks. It is also helpful in outdoor areas where temperature changes can stress fish because their thick walls provide great thermal mass, which helps to stabilise water temperatures by absorbing heat during the day and releasing it at night. This is especially effective in circumstances where the water temperature fluctuates. However, there are a few significant drawbacks associated with concrete tanks. The construction of these systems is costly, both in terms of the materials used and the labour required, which makes them less suitable for systems that are either smaller or more cost-conscious. Concrete tanks that have just been

**TransFarm**

constructed may also leak lime into the water, which can cause the pH levels to rise and necessitate proper drying and sealing before they can be used. This preliminary maintenance process is essential to prevent the fish from being harmed. After they have been created, concrete tanks are perfect for the cultivation of large, hardy fish species such as tilapia and carp, which can flourish in stable habitats, high-capacity, and have water parameters that are under control.



*Figure 10. Concrete fish tanks in Latvian aquaculture system.<sup>2</sup>*

**Metal Tanks (Lined with Food-Grade Coatings)**

Metal tanks, which are often constructed from galvanised steel or aluminium, remain a viable alternative for aquaponics systems, particularly when they are lined with food-grade coatings or liners. Metal tanks are a less frequent option than other types of tanks. The inherent robustness of metal tanks makes them extremely durable and resistant to harm from the environment. Additionally, the huge capacities of these tanks make them suited for use in commercial operations or larger systems that demand higher amounts of water. When space is limited yet a high fish stocking density is necessary, metal tanks are particularly effective because of their ability to accommodate many fish. On the other hand, since metal is prone to corrode, particularly when it is exposed to water and varying temperatures, these tanks need to be lined with non-toxic, food-grade materials such as plastic or rubber to prevent dangerous compounds from seeping into the water. Metal tanks, in the absence of appropriate linings, provide considerable dangers to the health of fish and the purity of the water. Metal tanks have poor thermal insulation, which is one of their negatives. Metal is a material that readily transfers heat, which means that the water temperature can change more easily. This is especially true in habitats that are exposed to the elements, which can be stressful for fish species that are sensitive to temperature. Additionally, the initial cost of metal tanks and their linings can be rather substantial, which makes them less appealing for budget-friendly setups. Despite these obstacles, it is possible to successfully raise fish species such as tilapia and trout in metal tanks, providing that the water temperature is managed appropriately.

**Intermediate Bulk Containers (IBCs)**

---

<sup>2</sup> <https://bior.lv/en/node/738>

## TransFarm

On a modest scale and in do-it-yourself aquaponics systems, intermediate bulk containers, often known as IBCs (Figure 11), are among the tanks that are utilised the most frequently. Many people who are interested in aquaponics find that these containers, which were first developed to transport liquids, are constructed from food-grade plastic and are encased in a metal frame. This makes them an alternative that is both affordable and easily available. IBCs are compact enough to fit in backyards or urban environments, while they still give sufficient volume for a range of fish species. Their usual capacity is approximately one thousand litres, making them ideal for transporting fish. In addition to being inexpensive, IBCs are also very simple to modify, which is one of its most significant advantages. Because they can be cut, drilled, and fitted with piping, they can be integrated into any system design without any inconvenience. On the other hand, their plastic walls may deteriorate with time if they are exposed to direct sunlight; therefore, it is essential to offer shade or cover them with reflective material to extend their lifespan. IBCs have a restricted volume, which makes them less suited for bigger commercial systems or for fish that require more space. This is another disadvantage caused by the limited volume of IBCs. The narrow apertures of IBC tanks can make it difficult to access all of the areas included within the tank, which is another reason why cleaning these tanks can be somewhat tough. IBCs are a good alternative for breeding resilient fish species such as tilapia, catfish, and koi, which can adapt to reduced water volumes and different conditions. Despite these restrictions, IBCs are an ideal choice for raising these fish species.

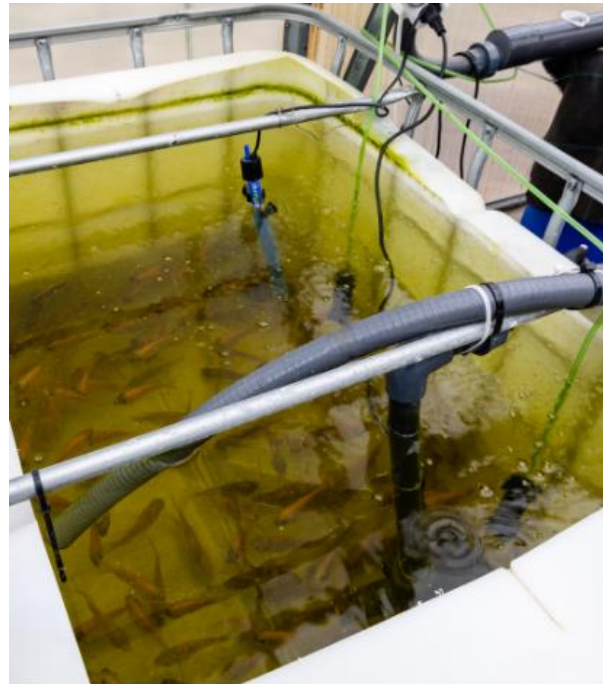

*Figure 11. An IBC (Euro-cube) used for fish cultivation in an aquaponics system.*

## Repurposed Aquariums

Repurposed aquariums are commonly utilised in small aquaponics systems that are housed indoors. These systems are frequently included in instructional or ornamental settings. Both glass and acrylic are commonly used in the construction of these tanks. Both materials provide great vision, which makes it simple to check the health of the fish and the clarity of the water. The aesthetic appeal of aquariums makes them excellent for demonstration projects or home-based systems where the fish and plants are intended to be displayed. Other applications include demonstration projects. Although aquariums are available in a wide range of sizes, their capacity is typically restricted in comparison to that of other types of tanks. As a result, aquariums are not ideal for the cultivation of fish that are larger or in greater numbers. On top of that, glass aquariums are delicate and prone to cracking or shattering if they are not handled with care. Even though acrylic aquariums are more robust, they are susceptible to becoming scratched over time, which may diminish their aesthetic appeal. In addition, aquariums are rather expensive, especially as the size of the tank increases. This might be a limiting issue for individuals who are interested in expanding their systems. Despite these limits, aquariums are an excellent environment for keeping smaller and decorative fish species such as goldfish, koi. However, larger fish species such as tilapia can also be kept in larger aquarium systems, providing that the water quality is carefully regulated.



The selection of the appropriate kind of fish tank for an aquaponics system is of the utmost importance to guarantee the overall success of the operation. Every style of tank has its own set of benefits and drawbacks, which can have an impact on the water quality, the health of the fish, and the maintenance of the system. Plastic and IBC tanks are ideal for smaller systems and offer cost-effectiveness, while fibreglass and concrete tanks offer durability and scalability for bigger operations. Plastic tanks are also acceptable for use in smaller systems. Even though they are sturdy, metal tanks need to be lined and insulated. Repurposed aquariums are perfect for educational or decorative purposes because of their versatility. The selection of the fish tank has to be in accordance with the particular requirements of the system. These requirements include the kind of fish that are being farmed, the scale of the system, system flexibility for expansion and the budget that is available.

### 3.2. Removal of sludge, mechanical filters

It is essential to manage organic refuse, such as feed waste, dead fish, and faeces, in aquaponics systems to ensure the health of the system and the quality of the water. The outlet box, which is occasionally referred to as a tank cleaner, is one of the primary instruments for managing waste in fish tanks. This device collects and removes solid refuse, thereby reducing the likelihood of organic buildup that can compromise water quality and ensuring that the water remains cleaner. Even though certain systems are initially designed with outlet boxes, the necessity for these devices may arise as a result of changes, such as the substitution of fish species, as certain species may generate more refuse or have distinct environmental requirements. Outlet receptacles also function as indicators of feed efficiency and fish welfare. This could indicate overfeeding, high stocking density, environmental stress, or emergent health issues within the fish population if excess feed or dead fish begin to accumulate in the outlet box (Figure 12).

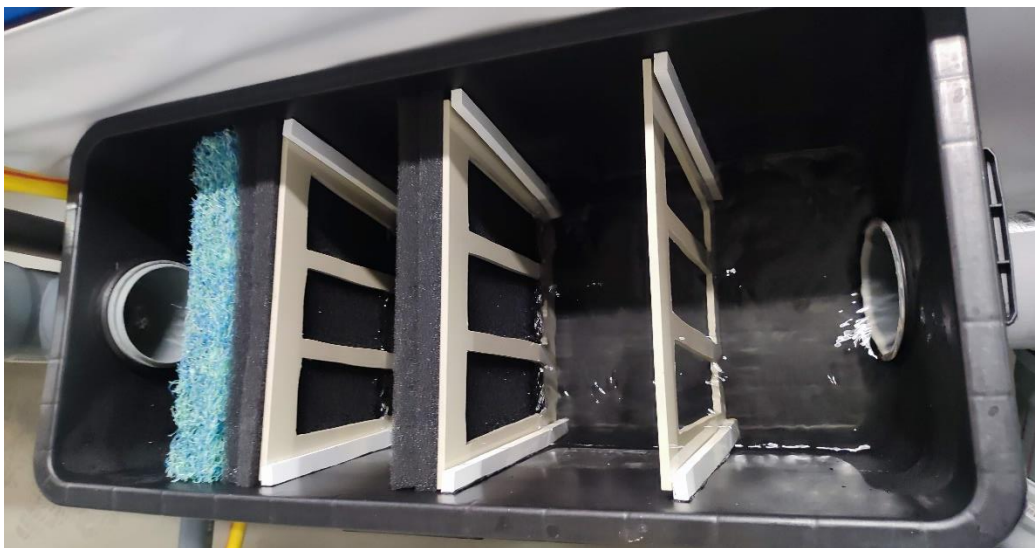

*Figure 12. A mechanical filter for sludge removal in an aquaponics system.*

Sediment removal is the subsequent priority after refuse exits the tank, and it is frequently accomplished using drum filters or lamella clarifiers (Figure 13). Lamella clarifiers are especially beneficial in systems with low water exchange rates and diminished water velocity, as they are engineered to slow down the flow of water, thereby facilitating the efficient sedimentation of solids. In these configurations, sediment removal is more efficient, resulting in a cleaner environment and a reduction in the burden on downstream biofiltration. The angled plates of a lamella clarifier promote sedimentation, which aids in the removal of solid refuse and maintains the nutrient balance and clarity of the water in the system.

TransFarm

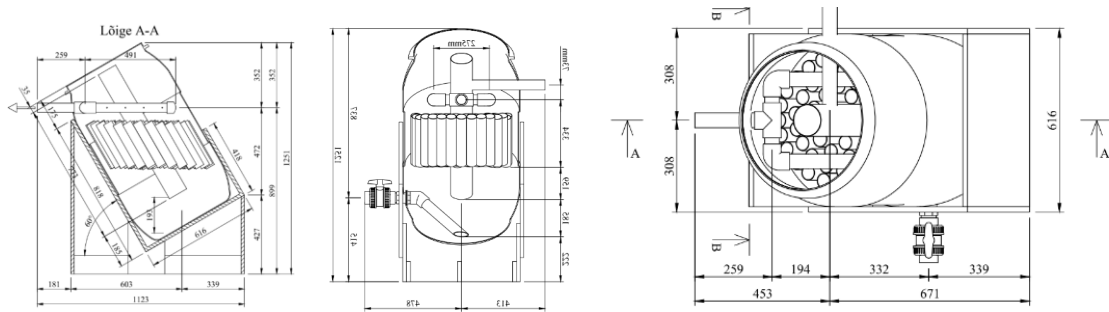

Figure 13. Lamella clarifier used in EULS (Estonian University of Life Science) experimental aquaponics unit.

Another valuable option for more compact and autonomous filtration is combifilters (Figure 14), which are designed to maintain the purity of water by removing organic particles in a smaller space. The combifilter's capacity and size are determined by the biomass of the fish and the volume of the aquaculture system. This is necessary because the biofilm carrier within the filter must accommodate the maximal daily feed load. This makes combifilters the optimal choice for medium-scale systems that require effective filtration to maintain healthful water quality, despite the limited space available.



Figure 14. mechanical filters and biofilters for removal mechanical removal of sludge from the fish tank.

Drum filters are among the most sophisticated and effective filtration systems available in commercial aquaponics on a larger scale (Figure 15). Drum filters are essential for the reduction of the organic waste burden in the aquaculture system, as they mechanically filter the water that exits the fish tanks. Microscreen filters with fine mesh, typically ranging from 20 to 100 microns, are employed by nearly all contemporary recirculated fish farms to eliminate even the smallest organic particles. The drum filter, the most prevalent variety of micro screens, is designed to remove waste particles gently and effectively by rotating continuously. Water travels through the micro screen as it enters the drum, propelled by the disparity between the water levels inside and outside the drum. Organic particles are contained on the screen and transported to a backwash area by the drum's rotation. High-pressure water jets spray from the exterior, dislodging the particles into a sludge accumulation tray. This sludge, which contains concentrated organic material, can be either utilised within the aquaponics system to serve as a nutrient-rich supplement for plants or directed out of the recirculated aquaculture system for further treatment.

**TransFarm**

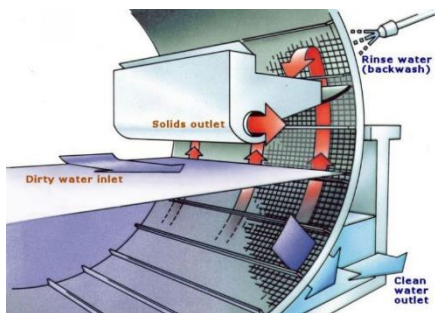

Figure 15. A drum filter for sludge removal.

Microscreen filtration provides numerous benefits that contribute to the stability and efficiency of aquaponics systems. These filters prevent clogging and increase the efficacy and lifespan of biofiltration processes by decreasing the organic load on biofilters. Furthermore, the purification of water by the removal of organic particles enhances its clarity, which in turn enhances the conditions for nitrification, a critical process that converts ammonia to nitrates, which are utilised as nutrients by plants. Plant growth and fish health are directly influenced by the stability provided by efficient micro screen filtration, as the

overall ecosystem in aquaponics systems is supported by balanced water quality, thereby enhancing productivity and sustainability.

3.3. Disinfection and aeration of water

Keeping the water quality in aquaponics systems in good condition is of the utmost importance because the lives of both fish and plants are greatly dependent on the presence of clean, oxygen-rich water. Aeration and disinfection are two water management practices that are of the utmost importance. The process of disinfection helps to prevent harmful infections and toxins from harming the system, while aeration ensures that fish have adequate oxygen to grow. When it comes to fostering a balanced and healthy environment within the system, both strategies are essential. However, alternative ways can be utilised depending on the size, complexity, and objectives of the aquaponics setup.

*Water Disinfection Methods in Aquaponics*

Disinfecting the water used in aquaponics is done to prevent the accumulation of hazardous pathogens, bacteria, and other impurities that could be detrimental to both the fish and the plants. Even though aquaponics is a system that is mostly capable of self-regulating, with helpful bacteria digesting fish waste into plant nutrients, it is still essential to take precautions against the dangers that are posed by microorganisms that are toxic to plants. It is normal practice to employ several different methods for disinfecting water, each of which has both positive and negative aspects (Figure 16).

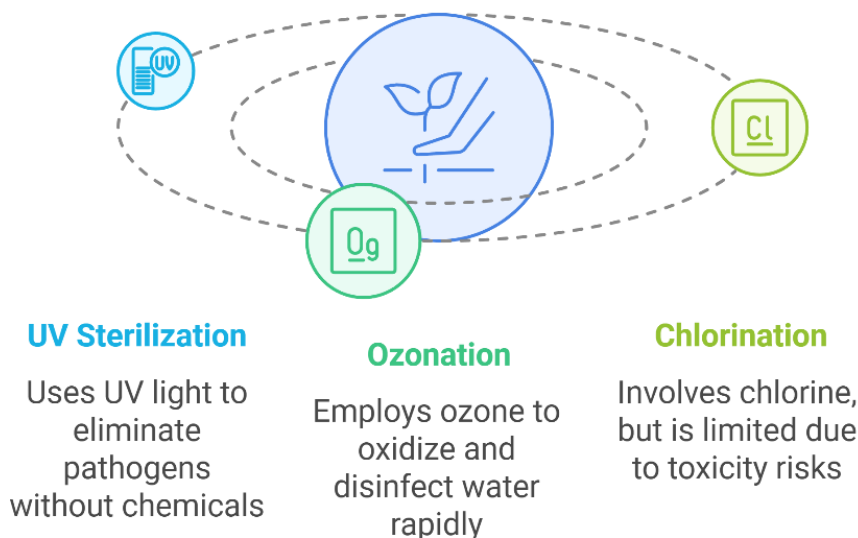

Figure 16. A summary of methods used for water sterilisation.

### **Ultraviolet (UV) Sterilization**

In the field of aquaponics, ultraviolet (UV) sterilisation is considered to be one of the most efficient practices for disinfecting water and is also commonly utilised. UV sterilisers are devices that operate by exposing bacteria, viruses, and parasites to ultraviolet radiation to kill or neutralise them by causing damage to their DNA, which prevents them from reproducing. This method does not involve the use of any chemicals, which makes it an excellent choice for aquaponics systems. It does not introduce any dangerous elements into the water that could have an impact on the fish or the plants. Since it does not modify the pH, oxygen levels, or any other chemical qualities of the water, UV sterilisation is also considered to be non-invasive.

UV sterilisation is advantageous for a number of reasons, the most important of which is that it is effective in removing a wide variety of pathogens. This is especially true in recirculating systems, where water is continuously filtered through the steriliser. This aids in the prevention of outbreaks of diseases such as columnaris and fin rot, both of which have the potential to rapidly spread among fish. The quality of the water is a critical factor in determining how effective UV sterilisers are. Water that is cloudy or unclean can obstruct the ultraviolet radiation, which in turn reduces the efficiency of the steriliser. Furthermore, in order to guarantee performance that is consistent, UV sterilisers need to undergo routine maintenance, which includes the replacement of the bulbs. In spite of the fact that it requires maintenance, ultraviolet (UV) sterilisation is especially useful in bigger systems where the spread of disease could have disastrous consequences.

### **Ozonation**

Ozonation is another way of disinfection that is particularly well-suited for commercial or large-scale aquaponics systems. For the purpose of eliminating bacteria, viruses, and fungus from water, this technique involves injecting ozone (O<sub>3</sub>), which is a highly reactive type of oxygen, into the water for the purpose of disinfecting it. To accomplish its function, ozone oxidises organic materials, thereby transforming viruses and pollutants into chemicals that are less hazardous. Ozonation is a good choice for systems that have large fish stocking densities or where it is difficult to maintain water quality because it is extremely effective and has a rapid onset of action.

One of the benefits of ozonation is that it may completely cleanse water without leaving behind any residues that could otherwise be dangerous. After the reaction, ozone also decomposes into ordinary oxygen, which has the potential to slightly increase the amount of oxygen that is present in the water. On the other hand, the installation and maintenance costs of ozonation systems are quite high. The production of ozone calls for the utilisation of specialised machinery, and the inappropriate handling of ozone gas can be quite dangerous. This is due to the fact that excessive concentrations of ozone can render fish and humans toxic. As a result of this, ozonation is often reserved for high-end commercial aquaponics setups. This is because the advantages of rapid and complete disinfection exceed the costs and complexity of the system.

### **Chlorination**

In spite of the fact that chlorination is a prevalent practice in many water treatment procedures, it is not typically utilised in aquaponics systems because of the negative impact that chlorine has on both fish and plants. Even minute amounts of chlorine can cause stress or even death in aquatic organisms, including fish and plants. Chlorine is extremely hazardous to aquatic life. However, in certain circumstances, chlorinated water may be utilised in the beginning stages of the cleaning process for tanks or equipment; however, it must be dechlorinated completely before being introduced into the

**TransFarm**

system. Utilising chemical neutralisers such as sodium thiosulphate or allowing water to sit for a length of time to allow the chlorine to evaporate are also methods that can be utilised to achieve dechlorination.

Among the many disadvantages of chlorination, the most significant one is the threat it poses to the ecological equilibrium of the aquaponics system. Beneficial bacteria that convert ammonia into nitrites and nitrates are very sensitive to chlorine, and there is a possibility that even a brief exposure to chlorine could disturb the nitrogen cycle. For this reason, chlorination is not a preferred technique of disinfection in aquaponics, with the exception of extremely rare and controlled scenarios in which water is treated independently from the system and after it has been completely dechlorinated before it is used.

*Aeration Methods in Aquaponics*

A suitable amount of oxygen is required for aquaponics systems to support fish health and the biological processes that are responsible for sustaining the system. This is in addition to the fact that water quality must be maintained through disinfection. This is because fish, plants, and beneficial microorganisms all require oxygen in order to function properly, making aeration an extremely important process. The presence of inadequate oxygen in water can result in the suffocation of fish, the wilting of plants, and disruptions in the nitrogen cycle, which can lead to the accumulation of ammonia, which can be harmful to fish. Depending on the size and complexity of the system, there are a few different aeration strategies that are often employed in aquaponics systems. Each of these techniques is designed to maintain ideal oxygen levels with the system (Figure 17).

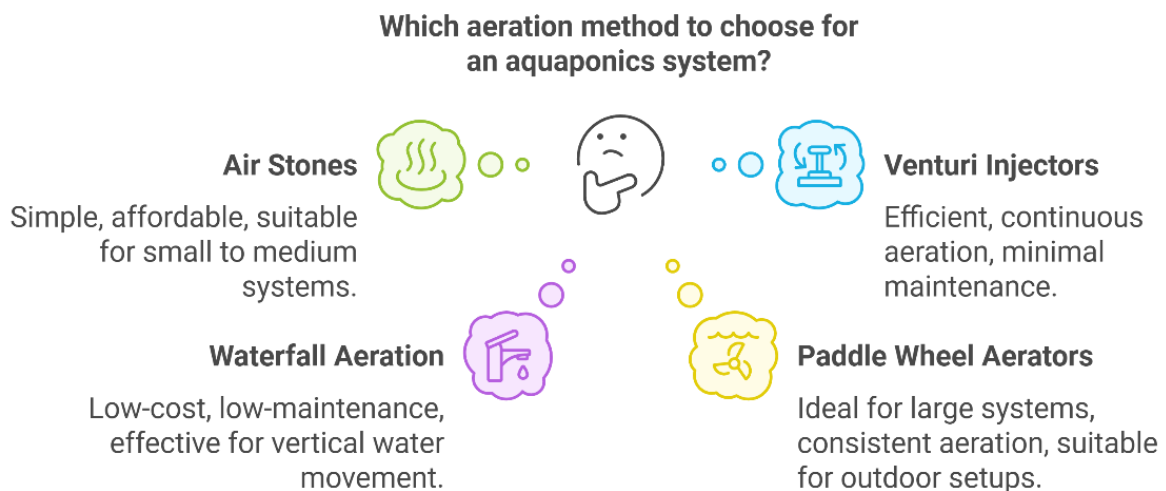

*Figure 17. A summary of water aeration techniques commonly used in aquaculture.*

**Air Stones and Diffusers**

Air stones and diffusers are two of the most prevalent and cost-effective ways of aeration in aquaponics (Figure 18). They are also one of the most common methods. There are porous stones known as air stones that are used to create little bubbles out of the air that is pumped into the water. The presence of these bubbles increases the surface area of the water that is exposed to oxygen, which in turn makes it easier for oxygen to dissolve completely into the water. In order to guarantee that oxygen is distributed uniformly throughout the system, air stones are frequently connected to air pumps through tubing and positioned at the bottom of fish tanks or sump tanks using air stones.

## TransFarm

One of the most significant benefits of air stones is that they are easy to use, and they are inexpensive. Since they are simple to install, maintain, and replace, they are suited for use in systems that are either small or medium in scale. In shallow tanks or systems with limited water flow, where oxygen levels could normally become depleted, air stones are particularly beneficial because of their ability to replenish oxygen levels. However, the efficiency of these stones can change based on the size of the air stone and the quality of the crystal. In order to guarantee sufficient aeration, larger systems can call for the utilisation of numerous air stones or more powerful diffusers. As time passes, air stones may become clogged with algae or silt, necessitating periodic cleaning or replacement in order to keep their performance at a satisfactory level<sup>3</sup>.



Figure 18. Air-stones for dispersion of oxygen into the water.

### Venturi Injectors

One more common type of aeration is the use of venturi injectors, which are particularly useful in aquaponics systems that are larger or more complicated. The Venturi effect is a principle that involves forcing water through a pipe that is narrowed, which results in the creation of a vacuum that compels air to enter the water stream. A thin mist of air bubbles is produced because of this procedure, which is a very effective method for boosting the amount of oxygen present in the water. There is the possibility of incorporating Venturi injectors into the water flow of the system. These injectors are often put at sites when water is being pushed between tanks or through filters.

The capacity of Venturi injectors to aerate water without the application of extra pumps or equipment is one of the advantages of using these injectors. Venturi injectors are able to provide continuous aeration with minimal maintenance since they make use of the water flow that is already present in the system. In addition, because they generate very small bubbles, they provide a large surface area for the exchange of oxygen, which makes them more effective than the conventional air stones. However, in order for Venturi injectors to perform well, proper calibration and maintenance may be required. Additionally, these injectors are most suitable for use in systems that have powerful water pumps. There is a possibility that this strategy will not be as beneficial to systems that have a low water flow or pressure. Instruction on how to create Venturi injectors are available or can be bought as a ready-to-use solutions<sup>4</sup>.

<sup>3</sup> <https://hydrobuilder.com/learn/air-diffusion-vs-air-stones-for-hydroponics/>

<sup>4</sup> <https://www.youtube.com/watch?app=desktop&v=OZMjDgM3LaU>

### Waterfall or Splash Aeration

In waterfall or splash aeration, water is allowed to fall from a height or splash over a surface, which creates turbulence and exposes more of the water to air (Figure 19). This type of aeration is a more passive method of aeration. When it comes to aquaponics systems, this technology is frequently incorporated organically into systems that contain cascading water features or where water is pushed between different levels of tanks. A good illustration of this would be the process of water splashing from a fish tank into a sump or grow bed, which causes the water to aerate and provide oxygen.

Waterfall aeration is a solution that is both low-cost and low-maintenance, and it is very effective for systems that already incorporate vertical water movement. Additionally, it functions most effectively in systems that have larger water flow rates, in which the amount of water that is being aerated is sufficient to satisfy the oxygen requirements of the fish and plants. However, it is possible that it will not be sufficient on its own for systems that are densely populated, as additional aeration may be required to keep the oxygen levels at an adequate level. In addition, water that is dropping from large heights can occasionally generate excessive splashing, which can result in water loss and necessitate careful planning in order to minimise wastage.<sup>5</sup>



Figure 19. An example of a floating splash/waterfall aeration device.

### Paddle Wheel Aerators

Especially in outdoor or pond-based aquaponics systems, paddle wheel aerators are frequently utilised in large-scale commercial aquaponics systems (Figure 20). These aerators make use of mechanical paddles to churn the surface of the water, which increases the amount of contact between the water and the air, so increasing the amount of oxygen that is absorbed. In most cases, paddle wheels are powered by either electricity or solar energy, and they can effectively aerate enormous amounts of water.

One of the most significant benefits of paddle wheel aerators is their capacity to oxygenate huge surface areas. As a result, these aerators are extremely well-suited for use in systems that contain extensive bodies of water, such as fishponds or large tanks. They can offer aeration that is consistent and reliable, which is especially crucial in systems that have a high stocking density of fish. Paddle wheel aerators, on the other hand, are relatively expensive to purchase and maintain, and the mechanical parts of these machines may need to be serviced on a frequent basis in order to maximise their lifespan. These systems are also better suited for outdoor applications, when the amount of space and water volume available is sufficient to warrant their utilisation.

<sup>5</sup> <https://www.agriexpo.online/prod/emygaqua/product-185779-107079.html>



Figure 20. Paddle wheel aeration devices in large-scale aquaculture units.

When it comes to the efficiency of an aquaponics system, the disinfection of water and the oxygenation of water are both absolutely necessary components that contribute to the overall success of the system. Ozone and ultraviolet (UV) sterilisation are two examples of disinfection processes that serve to keep microorganisms at bay without upsetting the delicate equilibrium that exists within the system. Techniques of aeration, on the other hand, guarantee that there is sufficient oxygen for the growth of fish, plants, and microbes that are beneficial to the environment. There must always be a sufficient level of aeration maintained, regardless of whether air stones, Venturi injectors, or more advanced systems such as paddle wheel aerators are utilised.

#### 4. Selection of the fish species

Below we present the main characteristics of some selected fish species to guide through the selection of the species. The selection is correlated to the environmental conditions and depends on economic considerations and market study.

The terms and parameters used are the following:

➤ **SGR, Specific Growth Rate**

It's a parameter that represents in percentage the increase of fish weight per day. Calculated by:

$$SGR = (\ln(W_t) - \ln(W_0)) * 100 / t(d)$$

where:

- $W_0$ [g]= the weight in grams at the beginning of the period;
- $W_t$  [g]= the weight in grams at the end of the period;
- $t$ [d]= period, expressed in number of days;
- $\ln$  = natural logarithm.

➤ **TGC, Thermal unit Growth Coefficient**

Measure of daily growth in each period that considers temperature. Calculated by:

$$GF3 = [(W_2^{1/3} - W_1^{1/3}) / \text{°D}] \times 1000$$

where:

- $W_2$  = weight (g) at time 2 (end of period);
- $W_1$  = weight (g) at time 1 (beginning of period);
- $\text{°D}$  = Degree-days, sum of daily temperatures in °C between  $t_1$  and  $t_2$  (or duration in days x average temperature in period).



➤ **FCR, Feed Conversion Rate**

It represents the amount of feed to produce a unit weight of fish. Calculated by:

$$FCR = \frac{W_t \text{ of feed given}}{W_t \text{ of animal produced}}$$

where:

$W_t$  = means the weight in a certain period.

4.1. Salmonoids

*Rainbow trout (Oncorhynchus mykiss)*

Rainbow trout is a salmon fish originally from the west coast of North America. It is easy to farm, and it has great taste. As with all salmonids, rainbow trout are sensitive to low oxygen levels and elevated temperatures. A stable pH value, high content of oxygen and continuous water circulation ensure this purpose. Rainbow trout are slaughtered after 10–12 months under optimal growing conditions. This fish converts feed to meat (the feed coefficient) efficiently and is easy to obtain as fry/smolt or even rum. It is quite common to slaughter rainbow trout just above 2 kg, but it is nowadays often farmed to 800–1500 g. This makes it possible to shorten the production time before slaughter and reduces competition with large Atlantic salmon. Fish raised in aquaponics compete with sea cage farmed salmon in the market. It is therefore important that one make accurate and realistic financial calculations to make sure sales can support the higher cost associated with RAS and aquaponics.



Figure 21. Rainbow trout (*Oncorhynchus mykiss*).

Table 1. Optimal growth conditions and other parameters for rainbow trout grown in aquaponics system.

<b>Farming temperatures:</b>	10 – 20 °C
<b>Optimal temperature:</b>	16 °C
<b>pH:</b>	6.5 – 8.5
<b>Oxygen concentration:</b>	DO > 6.5 mg/L; 100% saturation
<b>Recirculation degree:</b>	2 – 3 times/h
<b>Availability of eggs/fries:</b>	Yes
<b>Diet and Feed:</b>	Carnivorous species. There is special feed for trout, and it is easy to find out information.
<b>SGR (Specific Growth Rate):</b>	1.2 – 3.0
<b>TGC (Thermal Unit Growth Coefficient):</b>	2.5 – 3.0
<b>FCR (Feed Conversion Rate):</b>	0.9 – 1.1
<b>Density:</b>	30 – 60 kg/m <sup>3</sup>

**TransFarm**

<b>Time to reach the slaughter weight:</b>	10 – 12 months depending on the temperature, the initial weight, and the desired weight for slaughter.
<b>Slaughter weight:</b>	800 – 1500 g
<b>Water use per day and per kg of fish at 2 percent filling and density of 50 kg/m3:</b>	0.4 L

*Atlantic salmon (Salmo salar)*

Salmon is also very delicious fish to farm and has good growth rates. However, if you want to grow this fish to full size, you’re going to need a big fish tank for these to thrive.

Salmon take approximately two years to reach slaughter size. You’ll need to keep the water temperature between 12 °C and 16°C, and the water will need to be recirculated.



Figure 22. Atlantic salmon (*Salmo salar*).

Table 2. Optimal growth conditions and other parameters for Atlantic salmon grown in aquaponics system.

<b>Farming temperatures:</b>	7 – 20 °C
<b>Optimal temperature:</b>	12 – 16 °C
<b>Availability of eggs/fries:</b>	Yes
<b>Diet and Feed:</b>	Yes
<b>SGR (Specific Growth Rate):</b>	1.25 – 1.35
<b>TGC (Thermal Unit Growth Coefficient):</b>	2.0 – 3.0
<b>FCR (Feed Conversion Rate):</b>	1.0 – 1.3
<b>Density:</b>	30 – 60 kg/m <sup>3</sup>
<b>Slaughter weight:</b>	4000 – 5000 g

*Arctic char (Salvelinus alpinus)*



Figure 23. Arctic char (*Salvelinus alpinus*).

Table 3. Optimal growth conditions and other parameters for Arctic char grown in aquaponics system.

<b>Farming temperatures:</b>	12 – 14 °C
<b>TGC (Thermal Unit Growth Coefficient):</b>	1.65 – 3.0
<b>FCR (Feed Conversion Rate):</b>	1.0 – 1.4
<b>Density:</b>	30 – 80 kg/ m <sup>3</sup>
<b>Slaughter weight:</b>	1000 – 1500 g

#### 4.2. Percidae (perch and pikeperch)

##### *Perch (Perca fluviatilis)*

Perch is considered a warm water species because the optimum temperature for growth is above 20°C, but what is something special for the species is that it can also handle cold water down to or just above 0 degrees. The species is very adaptable and is therefore considered to have good opportunities in cultivation. Perch farming in RAS currently takes place on a small scale in Sweden but takes place on a slightly larger scale abroad in e.g. Ireland, Belgium, France and Switzerland. “Yellow perch”, is also produced on large-scale facilities in the United States. Perch, just like the salmon fish discussed above, is a predatory fish and needs a large proportion of protein in its feed. The need of protein decreases with the size of the fish but should still be mentioned when discussing sustainability aquaculture. However, there is more research and development in the feed industry and more vegetable protein is used in the feed. Other protein sources are used as well, such as e.g. mussels, yeast, micro-organisms, insects or residual products from the rest of the food industry in order to reduce the use of wild fish in the feed. A disadvantage that is often mentioned for the farming of perch and all warm water species in more northern latitudes is the cost of heating water to the optimum temperature for the fish growth. This cost is smaller the higher the degree of recirculation you have. Pumps, machines, indoor climate control and the large amount of heated water releases heat in the farming environment and this helps containing the heating costs. Another solution to take into consideration is industrial symbiosis, in particular the possibility of using waste heat from other industries to heat up the aquaponics facility.



Figure 24. Perch (*Perca fluviatilis*)

In some facilities cooling can require a greater cost than heating up water, especially when it comes to the salmon fish. All these aspects make perch, with its great temperature tolerance, a more interesting species for RAS. The Swedish market is keen to have perch fillets, and this gives the farmer a higher added value. With a fillet yield of around 35-40% the loss is up to 60-65% of the produced weight, but this loss is included in the price and perch fillets of good quality can be sold for a high price that covers the extra cost and exchange loss. The price of perch can also vary depending on the amount of wild caught fish on the market. However, one advantage of RAS is that the farmer can plan his business and slaughter, so that it does not coincide with a low market price.

TransFarm

Table 4. Optimal growth conditions and other parameters for perch grown in aquaponics system.

<b>Farming temperatures:</b>	16 – 28 °C
<b>Optimal temperature:</b>	23 – 26 °C
<b>pH:</b>	6.5 – 8.5
<b>Oxygen concentration:</b>	4.0 – 10.0 mg/l
<b>Recirculation degree:</b>	1 – 3 times/h
<b>Availability of eggs/fries:</b>	No - collects rum from the wild stock.
<b>Diet and Feed:</b>	Carnivorous species. Special feed is available.
<b>TGC (Thermal Unit Growth Coefficient):</b>	0.6 – 1.6
<b>FCR (Feed Conversion Rate):</b>	1.1 – 1.4
<b>Density:</b>	40 – 70 kg/m <sup>3</sup>
<b>Time to reach the slaughter weight:</b>	About 12 months.
<b>Slaughter weight:</b>	300 – 400 g
<b>Water use per day and per kg of fish at 2 percent filling and density of 50 kg/m<sup>3</sup>:</b>	0.33 l

*Pikeperch (Sander lucioperca)*

There are natural stocks in pretty much all of Europe and up to southern Norrland in Sweden. Pikeperch is a freshwater predatory fish that, quite quickly after hatching, begins to eat other fishes. It can be considered a disadvantage in the farming context because pikeperch is a cannibal. In land-based cultivation where you have controlled growing conditions, it is possible to take measures to reduce the effect of cannibalism. Sorting by size is a measure to maintain an even body size between individuals. Even-sized pikeperch reared under high density behave like shoal of fish and that, along with good access to food, minimizes cannibalism. Pikeperch produces a lot of rum but just like for perch, it is rum from the wild stock used in farming today. However, there are good opportunities to change behaviour and/or increase the number of equal-sized individuals through breeding work. There are some large investments in pikeperch farming in RAS within Europe (e.g. in Denmark and the Netherlands). As there seems to be an increasing interest in pikeperch, work is also underway to develop a bred pikeperch that is more adapted to farming with faster and more even growth between individuals and a reduction in cannibalism. Pikeperch, which are often grown to between 1-1.5 kg, can be sold as cleaned fish without having to be further processed into fillets. This means that the yield will be up to 85-90% of the total fish weight and with a good price in the grocery store this can provide good economics in the business. Pikeperch can be slaughtered after 15 – 18 months depending on, among other things, water temperature and slaughter size target. It takes a little longer than perch to reach the slaughter size, but it is also growing faster and to a larger size in the end. This also makes the pikeperch an interesting fish species in RAS where the cultivation period most likely can be reduced as we learn more about pikeperch and its behaviour in farming conditions.



Figure 25. Pikeperch (*Sander lucioperca*).

Table 5. Optimal growth conditions and other parameters for pikeperch grown in aquaponics system.

<b>Farming temperatures:</b>	16 – 28 °C
<b>Optimal temperature:</b>	23 – 28 °C
<b>pH:</b>	6.5 – 8.5
<b>Oxygen concentration:</b>	4 – 10 mg/L
<b>Recirculation degree:</b>	1 – 3 times/h
<b>Availability of eggs/fries:</b>	No - collects rum from the wild stock.
<b>Diet and Feed:</b>	Carnivorous species. Special feed is available.
<b>TGC (Thermal Unit Growth Coefficient):</b>	0.8 – 1.7
<b>FCR (Feed Conversion Rate):</b>	1.1– 1.5
<b>Density:</b>	40 – 80 kg/m <sup>3</sup>
<b>Time to reach the slaughter weight:</b>	About 6-12 months 100 g to 600 g (16-22 °C)
<b>Slaughter weight:</b>	600 – 1500 g
<b>Water use per day and per kg of fish at 2 percent filling and density of 50 kg/m<sup>3</sup>:</b>	0.33 l

#### 4.3. Siberian Sturgeon (*Acipenser baeri*)

Siberian sturgeon is an ancient species of fish that has remained almost unchanged since it first appeared in fossils from about 250 million years ago. There are 27 species of sturgeon in the family Acipenseridae, spread across subtropical, temperate, and subarctic regions of North America and Eurasia. Most sturgeon species are anadromous and spend most of their adult lives in estuaries but swim upriver to mate and spawn, which only happens during the correct conditions and not in each year after puberty. It can take between 11 and 24 years for males and 20–28 years for females to reach sexual maturity in wild populations. Siberian sturgeons, which is the most farmed sturgeon species, produces caviar at an earlier age. Siberian sturgeon becomes sexually mature within 5–8 years of age under optimal farming conditions. Interest in sturgeon cultivation in RAS has increased in recent years. In Finland, there is an operative sturgeon farm since 2005, using waste heat from a paper factory and with a water recycling rate of >99 percent. Both caviar and meat from Siberian sturgeons and beluga are produced there. In addition to Finland, Siberian sturgeon is also produced in Russia, China, Poland, Spain, Germany, Italy, USA, Belgium, and Hungary, among others. In Sweden, two RAS sturgeon farms have been established in recent years. Both will produce meat and above all the sought-after luxury product caviar, for sale in Sweden, Russia, and the rest of the world. The sturgeon's plasticity for different environments makes it durable for breeding in RAS. Sturgeons require clear and oxygen-rich

TransFarm

water but can also handle lower oxygen levels for shorter periods. It can be grown under high densities (up to 80–90 kg/m<sup>2</sup>) if you can maintain a sufficiently good water quality but thrives and grows best under low densities around 15–25 kg/m<sup>2</sup>. Since sturgeon is farmed for both meat and caviar, it is important to know the sex of the fish. In terms of appearance, it is difficult to see any difference between the two sexes, and you therefore need to do this via ultrasound or biopsy. Males and females are then usually separated, and males are raised for the meat with an earlier slaughter age, while the females are used for caviar production for a longer period. Some farms use females for caviar production several times while other farms slaughter the females for meat after it has produced caviar once. Females do not produce rum every year and not synchronized within a cohort. The percentage of females that produce rum in a group can vary between 35 and 63 percent annually and gives an uneven production that should be factored into planning. Geosmin, a smell that comes from bacteria in the biofilter and can give an aftertaste to fish grown in Aquaponics, can also be problematic for sturgeon meat and above all caviar. Sturgeon like to eat from the bottom of the tank and the tanks therefore do not need to be deep, 1–1.5 m deep is enough. However, sturgeons need bottom space to find their food and therefore density is often calculated in square meters instead of cubic meters when it comes to sturgeon. In practice, if you use 1 m deep tanks, it will still be the same density, but if you have somewhat deeper tanks, it can be beneficial to think about what the space on the bottom in square meters is so that the sturgeon can get the food and grow normally. There are special feeds for sturgeons in pellet form, which in nutritional composition are like what is used for, for example, rainbow trout. On the other hand, you would like sturgeon pellets to be just as stable and sink faster and not dissolve as quickly so that these toothless animals will find and pick them from the bottom. Sturgeons produce an extremely valuable product, caviar, which can be very profitable for the farmer. But it takes time and therefore requires a large investment in both time and money. Some companies avoid the long waiting period at the beginning by buying in sturgeon that are already several years old. But even that requires a large investment as the fish becomes more expensive the closer it gets to sexual maturity. There is a market for the meat, above all in Eastern Europe and Russia, and could be marketed that way in Sweden as well.



Figure 26. Siberian Sturgeon (*Acipenser baeri*).

Table 6. Optimal growth conditions and other parameters for sturgeon grown in aquaponics system.

<b>Farming temperatures:</b>	14 – 24 °C
<b>Optimal temperature:</b>	17 - 20 °C
<b>pH:</b>	6.5 – 7.5
<b>Oxygen concentration:</b>	4 - 6mg/L
<b>Recirculation degree:</b>	1 – 2 times/h
<b>Availability of eggs/fries:</b>	Yes
<b>Diet and Feed:</b>	There is special feed for sturgeon
<b>SGR (Specific Growth Rate):</b>	1.2 – 1.6

TransFarm

<b>FCR (Feed Conversion Rate):</b>	1.5 – 1.8
<b>Density:</b>	15 – 25 kg/m <sup>3</sup>
<b>Time to reach the slaughter weight:</b>	About 1 year from 10 g
<b>Slaughter weight:</b>	1300 – 1500 g
<b>Water use per day and per kg of fish at 2 percent filling and density of 50 kg/m<sup>3</sup>:</b>	1 L

4.4. African Catfish (*Catfish gariepinus*)

Catfish is a fish species that is growing rapidly, not least on the African continent. In 2014, 237 thousand tonnes of Catfish were grown in Nigeria but also in Holland, Hungary, Kenya, Brazil, South Africa and Cameroon (FAO, FishStat). There are many different fish species of the genus Catfish both in Africa and Asia and several of these are used in fish farms. There are many different types of feed. When fish farming started on an intensive level in the 70s and 80s, in the tropics Tilapia and Catfish were often grown in the same farms. That means you can feed Catfish with Tilapia offal, but this can certainly be illegal in Sweden.

So far Catfish is grown only in RAS in Sweden. This is of course because the fish require warm water and therefore must be grown indoors. It is an extremely hardy fish that is resistant to many common diseases, can handle low oxygen levels and can grow at extremely high densities. Like several other fish, it can also manage to stay on land for longer periods and uses its mouth as a kind of lung to breathe air. The name comes from the Greek "chlaros", which means "lively" and is a good description of just how hardy the fish is. Catfish is an omnivore, which means that it can live on a high proportion of vegetable proteins in the feed. It grows extremely well and can reach a weight of 1.5-2 kg in 6 months and weighs around 3.5 kg after a year. The feed coefficient is slightly higher than, for example, for salmonids, but this can partly be explained by the fact that a considerable proportion of the feed is vegetable. Just as for tilapia and other omnivorous or herbivorous fish, vegetable feed makes it possible to manufacture feed based on, for example, residual products from agriculture. Uneven growth, especially among fry, can be a concern if you don't sort often because cannibalism is common among Catfish gariepinus. However, when the fish is around 12 weeks old, it shows much more even growth between individuals and regular sorting becomes less necessary the larger it gets. Mortality and disease are also not a major problem with this species.



Figure 27. African catfish (*Catfish gariepinus*).

Table 7. Optimal growth conditions and other parameters for catfish grown in aquaponics system.

<b>Farming temperatures:</b>	21 – 34 °C
<b>Optimal temperature:</b>	26 - 30 °C
<b>pH:</b>	6.0 – 8.5
<b>Oxygen concentration:</b>	3.5 – 6 mg/L

TransFarm

<b>Recirculation degree:</b>	1 – 2 times/h
<b>Availability of eggs/fries:</b>	Yes
<b>Diet and Feed:</b>	There is special feed
<b>SGR (Specific Growth Rate):</b>	2.5–3.5
<b>FCR (Feed Conversion Rate):</b>	1.2–1.6
<b>Density:</b>	60–200 kg/m <sup>3</sup>
<b>Time to reach the slaughter weight:</b>	8 – 12 months
<b>Slaughter weight:</b>	1500 – 3500 g
<b>Water use per day and per kg of fish at 2 percent filling and density of 50 kg/m<sup>3</sup>:</b>	0.15 L

4.5. Tilapia (*Oreochromis sp.*)

Tilapia, an African Cichlid, is the world's second most farmed fish with a production of around 3.6 million tons in 2014 (FAO FishStat) and is quickly catching up with carp, which is in first place. Tilapia is actually a collective name for a large group of several families (*Oreochromis sp.*, *Tilapia sp.*, *Sarotherodon sp.* and *Alcolapia sp.*).

These will probably change names so Tilapia is now a substrate spawning fish as opposed to *Oreochromis.sp* which is mouth brooding. Unlike *Oreochromis.sp*, *Tilapia.sp* are very aggressive and claim territory. *Sarotherodon sp.* and *Alcolapia sp* will probably be moved to *Oreochromis.sp*) of cichlids. It is grown in many parts of the world (>100 countries), especially in warmer areas such as China and the rest of Asia, many African countries, Central and South America and the USA. The USA is the largest importer of Tilapia (mainly from China) but also produces a lot themselves.



Figure 28. Tilapia (*Oreochromis sp.*).

The most commonly farmed "Tilapia species" is Niletilapia (*Oreochromis niloticus*) but there are, as above mentioned, many different species that are farmed all over the world. Tilapia is among the easiest fish to grow and fits very well in aquaponics. It is a hardy fish that can handle high densities, and it grows very quickly to the market size which is 400 g–1000 g on the Swedish market. As mentioned above, Nile tilapia is an omnivore and thus, unlike salmonids, it can survive and grow perfectly well on feed with 100 percent vegetable content. Not depending on fishmeal as feed produced from wild fishing is of course a big advantage when discussing sustainable production. However, almost all tilapia feed contains fishmeal and fish oil to both increase the growth rate and enable the fillets to contain the omega-3 unsaturated fish fats EPA and DHA that are beneficial for humans. As written above, the feed industry has also aimed for a more sustainable solution even for predatory fish and research is ongoing there as well for new protein sources that do not rely on wild



TransFarm

fish to an excessive degree. Due to the Nile tilapia's growth and reproductive characteristics, Tilapia can be a very successful invasive species if contained. However, it is not considered a problem in northern latitudes and especially not in aquaponic systems because the fish are kept indoors in tanks and, even if they could escape from the facility, they would not be able to survive and reproduce in the relatively cold water. Thanks to its fast-spawning cycle of 4-6 weeks Tilapia is well suited for so-called "staggered production". This means that you have fish of different ages in separate tanks. This means that you put in the same number of fry as fish you want to get out at slaughter. Then they are left in the same tank during all their life. You thus avoid moving fish too much and get an even and predictable production of both fish and green biomass.

Table 8. Optimal growth conditions and other parameters for tilapia grown in aquaponics system.

<b>Farming temperatures:</b>	21 - 36 °C
<b>Optimal temperature:</b>	26 - 32 °C
<b>pH:</b>	6.0 – 8.5
<b>Oxygen concentration:</b>	3.5 – 6.0 mg/L
<b>Recirculation degree:</b>	1 – 2 times/h
<b>Availability of eggs/fries:</b>	Yes
<b>Diet and Feed:</b>	There is special feed for tilapia
<b>SGR (Specific Growth Rate):</b>	2.0 – 3.0
<b>FCR (Feed Conversion Rate):</b>	1.1 – 1.6
<b>Density:</b>	60 – 160 kg/m <sup>3</sup>
<b>Time to reach the slaughter weight:</b>	6 – 7 months
<b>Slaughter weight:</b>	400 – 800 g
<b>Water use per day and per kg of fish at 2 percent filling and density of 50 kg/m<sup>3</sup>:</b>	0.2 L

4.6. Carp (*Cyprinidae spp.*)

Common carp (*Cyprinus carpio*) and other species of carp that can be farmed (Silver carp (*Hypophthalmichthys molitrix*) Grass carp (*Ctenopharyngodon idella*).

Carp come from Eastern Europe and Asia and are currently the most farmed fish species globally. Carp fish, are tolerant of relatively low oxygen levels and poor water quality, and they have a much larger tolerance range for water temperature. Carp can survive in temperatures as low as 4°C and as high as 34°C making them an ideal selection for aquaponics in both temperate and tropical areas. The best growth rate is obtained when the temperature is between 25°C and 30°C. Under these conditions, they can grow from fry to slaughter size (500-600 g) in less than a year (10 months). The growth rate decreases dramatically with temperatures below 12 °C. Male carp are smaller than females, but can still grow up to 40kg and 1–1.2 m long in the wild. In the wild, carp are bottom-feeding omnivores that eat a wide variety of foods. They prefer feeding on invertebrates such as aquatic insects, insect larvae, worms, molluscs and zooplankton. Some herbivorous carp species also eat stems, leaves and seeds from aquatic and terrestrial plants as well as decaying vegetation. Farmed carp can easily be trained to eat liquid pellet feed. Carp eggs are best obtained from hatcheries and dedicated breeding facilities. The procedure for producing young is more complicated than tilapia because spawning in female carp is induced by hormone injection, a technique that requires additional knowledge of the fish's physiology and experience. Carp can easily be farmed with other fish and this has been done for centuries. This practice mainly consists in growing herbivorous fish (grass carp), plankton-eating fish (silver carp) and omnivorous/detritus-eating fish (common carp) together to cover all food niches. In aquaponics, the combination of these three species, or at least grass carp with common carp, would

TransFarm

result in a better use of the food, since the former would feed on both pellets and crop residues while the latter would also search for waste that accumulates at the bottom of the tank. As mentioned, carp can also be grown in a facility with other fish species to broaden the supply to the consumer, or, because it is relatively easy to grow, as a "source of nutrition" in an aquaponic where the main product instead is usually the plants. The supply of roots, among other crop residues, would also be extremely beneficial to the nutrient pool in aquaponic systems, as their digestion by the fish and the successive waste mineralization would return most of the micronutrients back to the plants. Other carp species (ornamental fish) Gold or Koi carp are produced mainly for the ornamental fish industry rather than food fish. These fish also have a high tolerance for a variety of water conditions and are therefore good candidates for an aquaponic system. They can be sold to private individuals and aquarium shops for significantly more money as ornamental fish (*Cyprinus carpio*) compared to fish sold as food. Koi carp and other ornamental fish are a popular choice for vegetarian aquarists. In addition to the climatic characteristics and issues of fish management, the choice of a carp species to be grown in aquaponics should follow a cost-benefit analysis that considers the convenience of growing a fish that is bony and generally has lower market prices than other species.



Figure 29. Carp (*Cyprinus carpio*).

Table 9. Optimal growth conditions and other parameters for carp grown in aquaponics system.

<b>Farming temperatures:</b>	15 – 32 °C
<b>Optimal temperature:</b>	26 - 30 °C
<b>pH:</b>	6.5 – 8.5
<b>Oxygen concentration:</b>	3.5 – 6.0 mg/L
<b>Recirculation degree:</b>	1 – 2 times/h
<b>Availability of eggs/fries:</b>	Yes
<b>Diet and Feed:</b>	There is a special feed
<b>SGR (Specific Growth Rate):</b>	1.2–1.4
<b>FCR (Feed Conversion Rate):</b>	1.5–2.8
<b>Density:</b>	40–80 kg/m <sup>3</sup>
<b>Time to reach the slaughter weight:</b>	12 – 14 months
<b>Slaughter weight:</b>	400 – 2000 g

4.7. Crustaceans

Crustaceans offer benefits to an aquaponics system. They can be added to the aquaponics system along with some fish species or better yet, in a separate tank, usually the sump tank. The reason for

## TransFarm

this is that fish are prone to attack and eat crustaceans. Of course, crustaceans can also be raised as food for fish. The crustaceans eat dead organic plant material on the bottom of the fish tank. They thus help to keep the facility clean of suspended material. Shrimp and crayfish can also be kept in Deep Water Culture Systems under the rafts where they also keep the plant roots clean. Adding freshwater prawns (*Macrobrachium rosenbergii*), crayfish (*Cherax species*), and prawns to aquaponic systems have functional and economic benefits, but they require precise environmental control. Many crustaceans graze on uneaten fish food, biofilms, and debris, reducing waste and serving as a secondary crop. Crustaceans' nutrient cycling function reduces biofilter load by eating organic detritus, improving water quality for plants and fish. Crustaceans are more sensitive to environmental changes than many aquaponic fish species, therefore understanding their biological needs is crucial to their integration.

Crustacea are sensitive to ammonia, which is harmful even in low quantities, therefore water quality management is essential. To prevent crustacean physiological stress or death, ammonia levels should be below 0.5 mg/L and nitrite levels below 1 mg/L. Dissolved oxygen (DO) is important for respiration, development, and moulting, which is necessary for crustacean growth and shell renewal. To meet metabolic demands, oxygen concentrations should be above 5 mg/L. Moulting and exoskeleton formation are affected by water pH changes, thus it should be between 7.0 and 8.0. Due to stress on the crustacean's sensitive exoskeleton, sudden pH changes can cause shell abnormalities or death.

Each species has an ideal temperature range that affects growth, reproduction, and immunological response. Freshwater prawns develop best at 25–30 °C, while *Cherax* crayfish around 20–26 °C. A departure from these limits can delay growth, weaken immunity, and lower survival. If crustaceans are housed alongside cool-water fish like trout, segmenting or using thermal regulators may be needed to maintain this restricted thermal range in mixed-species systems. Maintaining crustacean development temperatures over 20 °C in chilly aquaponics systems is difficult but necessary to avoid delayed growth and decreased productivity.

Since crustaceans, especially crayfish, are nocturnal or prefer low light, lighting and photoperiod management are crucial. High-intensity illumination might stress and inhibit eating and growth. Bright settings without shade may make crustaceans less active and disease-prone. Hides, pipes and shaded spaces are essential for crustaceans, especially during moulting when they are most vulnerable. Since conspecifics can cannibalise moulting crustaceans, such shelters are necessary for population stability.

For strong growth, aquaponic crustaceans must be fed a balance of natural scavenging and additional nutrients. In productive farming systems, crustaceans absorb uneaten fish feed and biofilm, but these sources are rarely enough to supply their nutritional demands. Freshwater prawns need 35-40% protein to grow. A diversified diet of plant and animal stuff helps crayfish grow. Crustacean-specific pellets like fish meal or soybean are often needed. Calcium-rich meals like crushed shells or mineral supplements help form the exoskeleton, which is needed for moulting. Overfeeding can cause rapid ammonia production, thus proper feeding practices are needed for growth and waste prevention.

When crustaceans are present, biofouling and sedimentation must be monitored and controlled to prevent oxygen loss and infections. Keep buildup at bay with regular tank cleaning, sediment removal, and filter maintenance. Due to their foraging behaviour, crustaceans produce solid waste at the tank bottom, which sediment traps and small mechanical filters can reduce. Crustaceans' higher metabolic and waste production than fish increases biofilter demand, hence systems should include regular water exchange techniques to maintain ideal water conditions.

## 5. Fish feed/nutrition

In aquaponics, the maintenance of a balanced ecosystem is contingent upon the quality of fish feed and nutrition. Fish feed indirectly supports plant growth by providing essential nutrients through fish detritus, in addition to supporting the growth and health of the fish. The production of sufficient waste by fish to supply nutrients such as ammonia, which is converted into nitrates for plants by microorganisms, is contingent upon proper nutrition. Optimal fish development and immune function are facilitated by balanced nutrition, which is abundant in protein, lipids, vitamins, and minerals. It is imperative to regulate water purity, fish nutrition, and feeding rates to optimise the productivity of both fish and plants and to preserve the stability of the system (Figure 30).

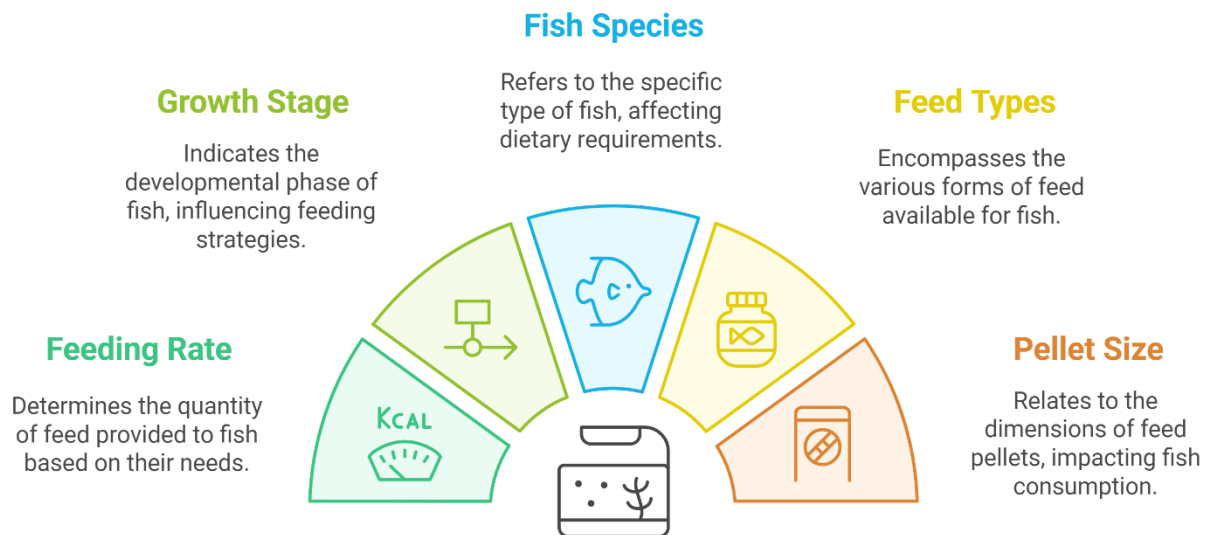

Figure 30. Summary of most important aspects regarding selection of fish feed.

### 5.1. Fish feed types

Selection of the suitable fish feed type or combination of feed is essential for maintaining a productive aquaponics system. Aquaponics is largely dependent on the nutrients that are brought into the system by the feed and metabolized by the fish, therefore careful optimisation of the fish diet is very important. The choice of fish feed largely depends on the species of fish you are growing, the growth stage (size of the fish) and the overall goals (fish or plant production). Generally, three larger categories of fish feed can be used – commercial pellets (with several subcategories), natural and live feed and homemade supplementary feed. All the three categories mentioned can be used in combination with one another to provide the fish with balanced diets.

#### *Commercial fish feed types*

Commercial fish feed in general is tailored to meet the specific dietary needs of individual fish species or their growth stages, optimal feeding rates ensure healthy development and predictable results. Below is a breakdown of the different types of commercially available fish feed with their intended uses (Figure 31).

TransFarm



Figure 31. Pelleted commercial fish feed.

**Floating pellets**

Floating pellets are one of the most commonly used types of commercial feed that is used in aquaculture and aquaponics. As the name suggests, the pelletised fish feed floats on top of the water allowing the fish to feed on the surface of the water. Fish species like tilapia and trout prefer this type of feed since they are mid- to top-water feeders. Using floating feed allows the operator to monitor exactly how much of the feed is consumed at each feeding time, thus the feeding rate can be adjusted accordingly so as not to waste any food. Floating pellets also encourage the natural feeding instincts of several fish species and can be used in different growth stages. Several species, that are considered bottom feeders, for example, sturgeon, when grown in limited space, can quickly learn to feed on top water, therefore this type of feed is considered universal in some use cases.

**Sinking pellets**

Sinking pellets are a type of fish feed that is designed to sink to the bottom of the fish tank and are preferred by farmers who grow bottom-feeding species like catfish or specific types of carp. In systems where there is more than one species of fish that use the whole water column as their living space this type of feed is beneficial in the way that this feed sinks to the bottom and the bottom-feeders are not competing for the food with top-water feeders. Like other types of commercial feed, these pellets come in different sizes and formulations to meet the needs of fish in different growth stages. When using sinking pellets, it is advised to carefully monitor the feeding rates, since it is not apparent when excess food is left uneaten and therefore can cause accumulation at the bottom and later issues with the water quality.

**Slow-sinking pellets**

Slow-sinking pellets are a hybrid option that gradually sinks in the fish tank making them suitable for fish that feed at different levels of the water column. This type of feed is universal when growing a mix of species or species that prefer feeding in the middle of the water column. Compared to sinking pellets, these pellets offer more time for fish to eat the food and help avoid feed accumulation at the bottom of the tank. If a lot of top-middle feeders are present in the fish tank and there are also typical bottom-feeders, care should be taken that the bottom-feeders are sufficiently fed and that the food is not consumed by other fish in the tank.

## Species-specific feeds

Some species have specific requirements for their diet and require special formulations of feed. For example, carnivorous fish like bass or trout require more fats and protein than herbivorous fish like tilapia, which require less protein but more fibre. The species-specific feeds are optimised to meet the natural diet of the fish, providing an optimal balance of the main nutrients for optimal production. Some feeds can contain also some more exotic additives like probiotics or digestive enzymes that promote digestion and nutrient absorption. The species-specific feed also considers the type of feeding the specific fish requires and thus the pellets are either sinking or floating.

## Growth Stage feeds

Commercial fish feed can also be formulated for specific growth stages of the specific species of fish. Juvenile fish (fry) feeds are usually smaller in size and contain higher protein levels to support rapid growth. Growing fish (grow-out) feeds are designed so that the protein contents are 30-40%. Breeding fish (broodstock) feeds are used to feed mature fish involved in breeding, this type of feed is usually supplemented with extra vitamins, minerals or other additives to enhance the reproductive performance. Depending on the growth stage the feeds have different sizes so that the fish can easily ingest the food.

### *Natural live feeds*

Natural feeds are an excellent supplement to the commercially available fish feed, especially for species that naturally feed on insects, larvae, or other aquatic invertebrates. This type of feed is nutrient-rich and offers high levels of protein, fats, minerals and vitamins mimicking the food they would consume in their natural habitats. Providing live feed can stimulate natural behaviour and provide a sustainable alternative to feed that can be grown in a closed-loop aquaponics system.

## Insects and larvae

Insects and larvae, for example, black soldier fly larvae, mealworms (Figure 32), crickets and others are excellent sources of proteins and fats. Black soldier fly larvae are rich in protein (up to 45%) and fat, up to 35%, making them an exceptionally rich source of nutrients for fish like tilapia or catfish. Black soldier fly larvae can be easily cultivated on any type of organic waste, food scraps, or discarded crops that arise from the functioning of an aquaponics system. Using the waste-derived form, the aquaponics systems create a closed-loop operation, where the waste created from crops is transformed into fish feed. Mealworms and crickets are especially rich in essential fatty acids, vitamins and protein, which are also a great addition to the fish diet. By providing fish with insects and larvae you are essentially encouraging natural feeding behaviour, making the fish more active, and reducing boredom, which is especially important in confined environments.



Figure 32. Black soldier larvae (left) and mealworm (right).

### Aquatic Invertebrates

Brine shrimp, daphnia, bloodworm (Figure 33) and other aquatic invertebrates are commonly used aquaponics fish feed additives for fish like perch, tilapia or ornamental species (koi carp, goldfish). Brine shrimp are rich in protein and fatty acids and are suitable for consumption by juvenile fish or smaller fish species. Daphnia (or water fleas) are small aquatic invertebrates that are nutritious and easy to cultivate. Bloodworms (larvae of midge flies) are usually consumed by carnivorous fish. Bloodworms can be cultivated in separate fish tanks or ponds to provide a continuous supply of live feed, thus stimulating the natural foraging behaviours.



Figure 33. daphnia (left) and bloodworms (right).

### Earthworms

Earthworms are rich in protein (up to 60%) and essential amino acids. Earthworms can be cultivated as a part of a closed-loop aquaponics system through vermiculture. In vermiculture the crop and vegetable residues that are produced can be fed into the vermicompost bin, the waste is eaten by the earthworms creating more worms and compost (nutrient-rich compost) which can be used for the growth of seedlings, for example. Larger fish like catfish, carp, perch and others can use these worms in their diet – they are also rich in minerals and vitamins.

### Algae and Duckweed

Herbivorous and omnivorous fish species like tilapia, carp and others can use certain species of algae and duckweed as part of their diets. Duckweed is a fast-growing small-sized aquatic plant which can contain up to 40% protein and is rich in other beneficial nutrients like vitamins and minerals (Figure 34). Duckweed can be cultivated in small ponds or as a separate growth habitat integrated within the

TransFarm

producing aquaponic system. Ponds in the summer season tend to overgrow with duckweed, but care must be taken when feeding the fish with outside sources of duckweed since they can contain pests and pathogens that can affect fish and plant health. Algae can also be supplemented as part of the fish diet – they contain micronutrients and fatty acids that are beneficial for fish health and the immune system. Algae can be bought as dried powders with limited viability. Algae through feed can be carried out throughout the system and sometimes unwanted algae proliferation can occur, especially if the operator tends towards a more sterile environment.



Figure 34. Duckweed overgrown pond.

The ability to cultivate live supplies on-site is one of the primary benefits of utilising them in aquaponics. For example, earthworm vermiculture installations can flourish on plant trimmings and organic compost, while black soldier fly larvae farms can be established using food refuse. Daphnia and brine crustaceans can be cultivated in small, dedicated containers or ponds, ensuring a consistent supply of feed. In addition to reducing feed costs, the cultivation of live supplies on-site also establishes a closed-loop system that enhances system efficacy and reduces waste. Furthermore, it enables greater control over the quality of the feed, guaranteeing that the fish are provided with nutritious, pesticide-free feed sources that are specially designed to meet their unique requirements (Figure 35).

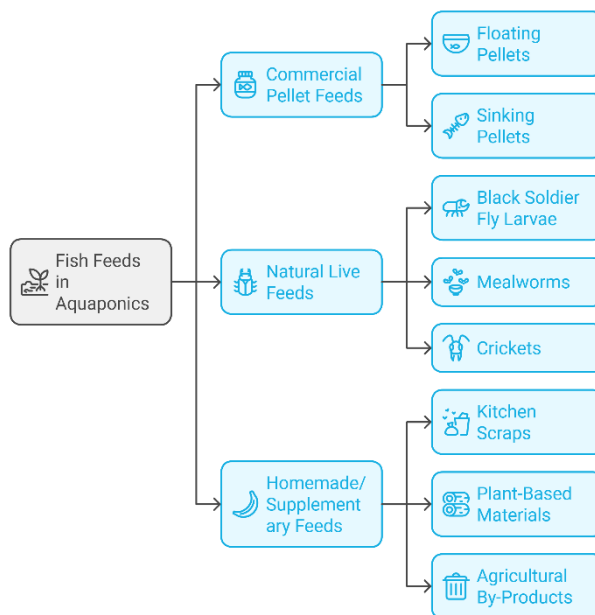

Figure 35. Types of fish feed that are commonly used in aquacultures.



## 5.2. Feed composition

Commercially available fish feed consists of a mixture of the main nutritive elements (protein and carbohydrates), vitamins and minerals which provide the fish with the necessary ingredients for sustainable growth. Fish are not very different from other animals based on their nutritional needs. Fish feed is mainly made up of protein, fat, and mineral substances which are derived from cereals, soybeans, corn, rice, wheat etc. The amount of each group of nutrients depends on the fish species that are being grown – the diet of specific fish must be nutritionally balanced and optimised for maximum growth potential, palatable, water stable and have the size of pellets adjusted for the fish size (Figure 36).

**Protein** is considered one of the main ingredients in aquaculture and aquaponics. Protein is the main macronutrient which is the building block for the growth and development of fish. Proteins consist of amino acids which are used by all living organisms for the synthesis of new tissue, enzymes, hormones and other vital compounds. In an aquaponics system, the protein in the fish feed directly influences fish health and growth rates, as well as the resulting water quality which is derived from the feed composition. High-quality and easy-to-digest sources of protein ensure that the fish can efficiently convert feed into their mass. Balancing the protein contents of feed can also support fish health – through proper protein supplementation the immune system and ability to resist diseases, and withstand environmental stress is improved. Protein is needed for the support of fish health as well as overall aquaponics productivity. Since fish are not able to produce certain amino acids, these essential amino acids must be supplemented by feed. The digesting ability of the protein through fish metabolisms creates fish waste that is further used by plants in the form of nitrates. If protein in the fish feed is insufficient this can lead to stunted plant growth and susceptibility to diseases. Balancing the system by adjusting the protein contents of fish feed, feeding rates etc. is crucial to obtain proper cycling of the whole system and avoid accumulation of nutrients that can become toxic to both main organisms within the system.

Typical protein contents in fish feed largely depend on the species of fish and their growth stage within the system. For juvenile fish (fry) the protein content is typically higher to promote faster growth, typically 40-50% protein. Adult fish feed usually ranges between 25-35% protein. This protein content allows to maintain health and sustained growth. Carnivorous fish require higher protein content fish feed (40-45%), while herbivorous species prefer to feed with 25-30% protein. When choosing the feed for your fish it is also advisable to evaluate the protein source, whether it is animal-based protein or plant-based protein. The source of protein determines how digestible and nutritious the protein is for your chosen species of fish.

TransFarm

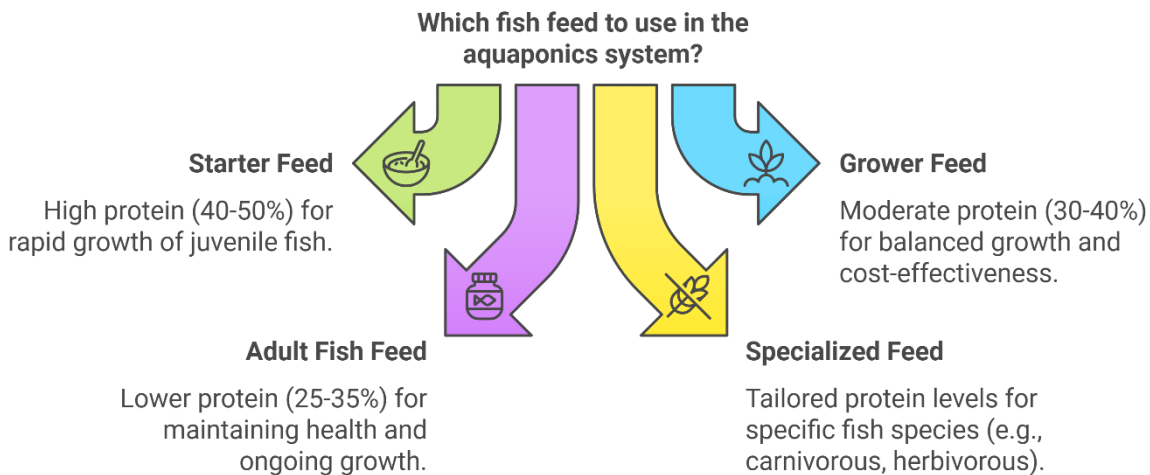

Figure 36. Types of commercially available fish feed.

**Carbohydrates** are added to fish feed as a source of energy, growth supporter and overall health-supporting ingredient (Figure 37). Most commonly as a carbohydrate different types of grain are used, for example, corn, wheat, barley and rice. Grains are rich in starches which are the main sources of energy. Legumes, especially soybean meal or peas are also often included in fish feed formulations, these sources are rich in both, protein and carbohydrates, contributing to overall nutritional balance. Other sources of carbohydrates include roots (potatoes, sweet potatoes) seaweed or algae (contain polysaccharides) or different by-products from other industries like molasses, brewers or distillers spent grain etc.

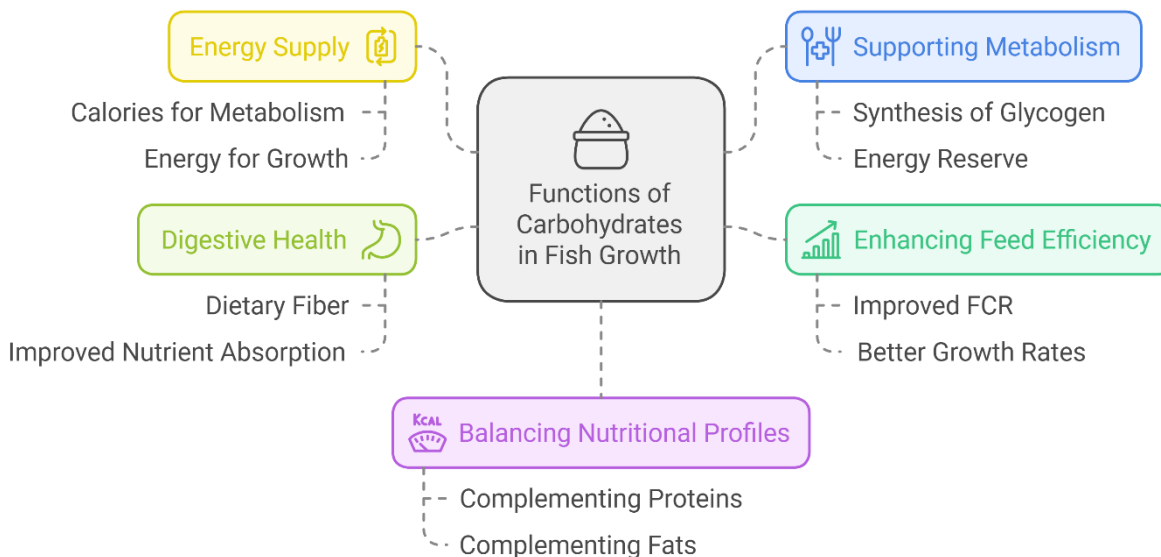

Figure 37. Carbohydrate functions in fish feed.

Carbohydrate balance in fish diets contributes to a steady energy supply (carbohydrates are the primarily used source of energy), metabolism support, digestive health (dietary fibre promotes gut health), and overall balance of the feed formulation. Incorporation of appropriate carbohydrate sources in fish feed is essential to support energy needs, enhance growth and ensure overall fish health. Starter feed usually contains 25-30% carbohydrates while adult and grower feeds contain 30-40% carbohydrates. Specific fish feed for carnivorous species usually contains lower levels of carbohydrates, typically 15-25%.

## TransFarm

**Fats and oils** are essential components of fish feed that provide the fish with energy and contribute to overall health and growth. Commonly fats that are added to fish feed are derived from the processing of fish meal. Fish oil (marine-derived oils) added to fish feed are rich in omega-3 fatty acids EPA (eicosapentaenoic acid) and DHA (docosahexaenoic acid). Animal fats derived from poultry, beef or pork can also be used in the fish feed, however, they are less rich in the essential omega-3 fatty acids. Algal oils on the other hand are rich in EPA and DHA and are proposed as more sustainable alternatives to fish oil, however, the price of algal oil is higher. Also, vegetable oils can be used, usually made from canola, corn, soybean or palm – generally, these are regarded as more sustainable and are also rich in other omega fatty acids.

The added fats are regarded as a more concentrated form of energy – one unit of oil provides the same amount of energy as one unit of carbohydrates or protein. The essential omega-3 and omega-6 fatty acids are crucial for fish health – they provide cell membrane integrity, hormone production, immune function and others. DHA, for example, promotes healthy brain development and function and improves the cardiovascular health of fish. The inclusion of quality fats in the fish diet can enhance feed conversion, thus promoting their efficient growth and improving weight gain with less feed.

Starter feeds normally contain 10-15% fats, while grower feeds contain 15-25%. Carnivorous fish require higher fat diets where fish feed contains 25-30% fats. Too much fat in the feed can also cause adverse health effects to the fish, therefore it is important to balance the diet with protein and carbohydrates, as well as minerals and vitamins.

**Vitamins and minerals** are added to fish feed artificially since they play an essential role in various physiological processes involved in immune responses, growth, and reproduction and they can not be found in the other main ingredients in sufficient amounts to ensure the needs of the fish. Vitamins A, D, E, K and group B vitamins are added to the food to support various functions within the bodies of fish, similarly, the mineral nutrients Ca, P, Mg, Na, K, and trace minerals Fe, Zn, Cu, Mn, Se are added. When making your fish feed the minerals and vitamins can be added to the food in the concentration of 1-2% of the final mix, such ready products are being sold commercially. Other ingredients such as amino acids can also be added to the mixture to help the growth of the fish.

Ready-to-use fish feed is the most convenient form of feeding your fish. Quality assurance and product consistency are essential when trying to keep a balanced aquaponics system. However, the costs of the specific feed must be evaluated to reach the full economic potential of your system. To calculate the costs of specific feed you can take the nutritional value in kcal and divide it by the price to obtain the cost per kcal of feed. While cheaper options exist, the quality of the feed must also be taken into consideration, since aquaponics systems are very fragile to any external stresses. Changing the feed frequently might disrupt constant nutrient flow throughout the system and upset parts of the established ecosystem. Alternatively, it is also possible to create your fish feed this requires careful sourcing of ingredients and optimisation of the protein-carbohydrate-fat ration to meet your system's needs<sup>6</sup>. The feed can then be pelletised and used the same way as commercially available feed. Creating your fish food requires a lot of experimentation and adjustment to reach the full potential and optimal growth of the fish and further the plants within the aquaponics system<sup>7</sup>.

A variety of sources<sup>8</sup> to replace or substitute ingredients for fish feed, for example, seeds, fruit and vegetables, cereals, oil-bearing crops, feed ingredients derived from animals, and other miscellaneous

<sup>6</sup> <https://www.fao.org/4/x5738e/x5738e0g.htm>

<sup>7</sup> <https://fishfeedmachinery.com/Solution/nutritional-fish-feed-formulation.html>

<sup>8</sup> <https://www.fao.org/4/s4314e/s4314e0k.htm>

TransFarm

feedstuffs (seaweed, molasses, spent grain, yeast, lipids etc.) that are by-products of other industries have been suggested. More detailed information on fish meal preparation can be found here<sup>9</sup>.

Fish, in addition to fish feed, can also be supplemented with insects, larvae or other small invertebrates as a part of their diet. This is especially important to omnivores and carnivores that naturally consume this type of diet. Insects are rich in essential nutrients like protein, fats, and amino acids and they can promote immune functions and reproductive health. Black fly soldier larvae are rich in protein and fats, which is a good addition to the dry fish feed. In addition to their high protein content, insects such as flies and bugs are also abundant in essential fatty acids, vitamins (including B vitamins), and minerals (such as calcium, phosphorus, and iron). These nutrients are essential for the overall health of fish, as they promote appropriate growth, disease resistance, and an increase in the quality of their flesh. Omega-3 and omega-6 fatty acids, which are present in specific organisms, are particularly advantageous for fish, as they enhance reproductive success and promote cardiac health. In comparison to processed particle feeds, fish are frequently more attracted to live or natural feeds, such as insects and beetles. This enhanced palatability can result in improved feed efficiency and growth rates, as well as reduced feed waste and improved feed consumption. Fish are kept more active, and their natural behaviours are engaged by live feed, which stimulates their natural hunting instincts.

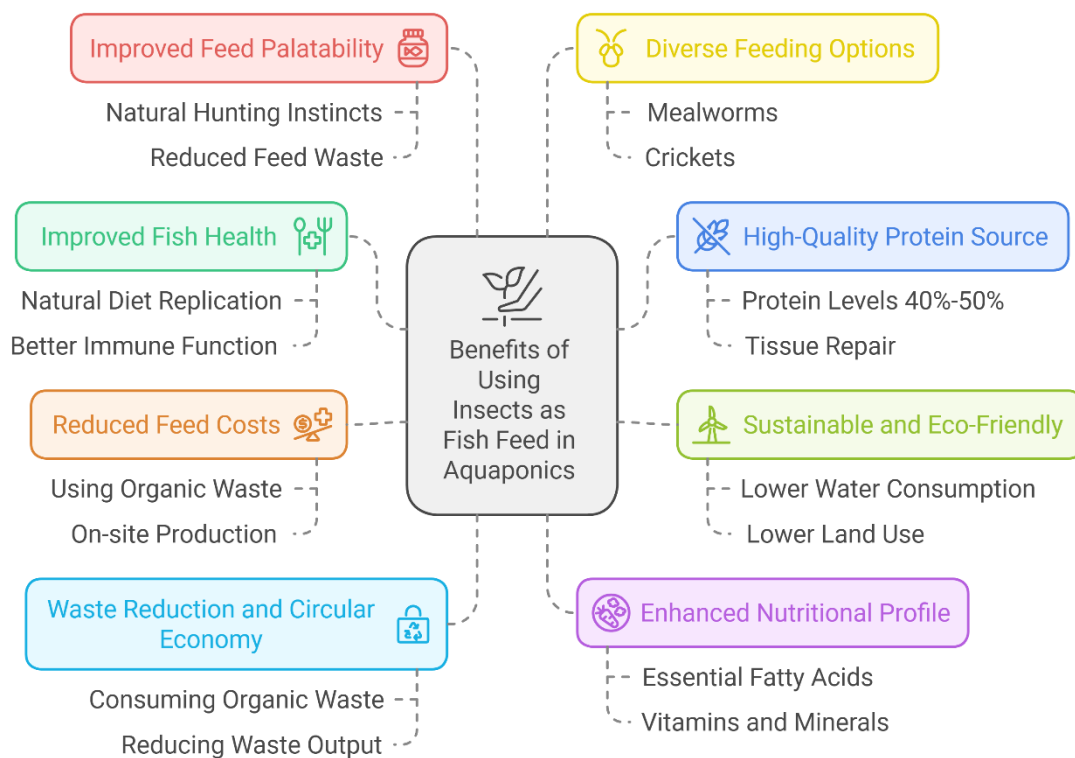

Figure 38. Advantages of natural feed use in aquaponics systems and aquaculture in general.

Black soldier fly larvae, in particular, are adept at consuming organic refuse, including food leftovers and plant material. Aquaponics operators can establish a closed-loop system in which organic waste is converted into high-quality fish nutrition by integrating these insects into the system. This contributes to a more circular and sustainable ecosystem and reduces the overall waste output, in accordance with the principles of sustainable farming and permaculture (Figure 38).

<sup>9</sup> <https://www.pelletizermill.com/blog/fish-feed-formulation-ingredients/>

### 5.3. Feeding rates

Several key factors can influence the feeding rates and thus the productivity of the whole aquaponics system. The main factors that must be considered when optimising the feeding rate of the fish are the specific species, size and growth stage, water temperature as well as other system conditions like nitrate and ammonium concentrations (Figure 39).

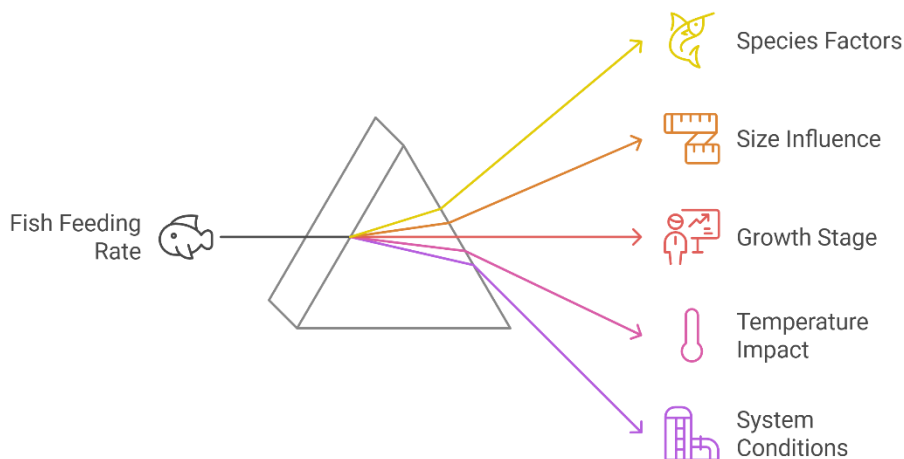

Figure 39. Summary of factors influencing the feeding rate.

Feeding rates are generally expressed as the percentage of the fish's body weight per day. Typically feeding rates range from 1% to 5% of the fish's body weight. An example – 1kg fish with a feeding rate of 1.5% would require 15 grams of feed (Table 10). Fish are typically fed one to three times a day depending on the species, water temperature or growth stage. Overfeeding the fish can lead to excess waste and issues with the water quality, while underfeeding can stunt the growth of the fish and limit the nutrients necessary for optimal plant growth.

Table 10. Depending on the species, different fish require different feeding rates.

Fish species	Feeding rate, %	The optimal temperature range for the indicated feeding rate, °C
Tilapia	1-3	26-30
Trout	1.5-2	10-18
Catfish	2-4	22-28
Barramundi	2-3	26-30
Goldfish	1-2	20-24
Koi	1-2	18-24
Perch	2-3	22-28
Carp	1-2	15-25
Bass	2-4	20-28
Cod	1-2	18-24
Pacu	2-3	24-28
Bluegill	2-3	20-27
Red claw crayfish	1-2	24-28
Sturgeon	1-2	14-20

The feeding rate should be adjusted based on the size, growth stage and temperature of the water. Generally, when the water temperature is higher, fish tend to consume more feed, and vice versa, when the temperature is lower, the metabolism of fish is reduced, thus reducing their food

requirements. Juvenile fish require higher feeding rates (often up to 5% of the body weight per day) to promote growth, while adult fish and broodstock require less feed (1-3%).

Feed rates can also be adjusted depending on the proposed conversion from fish feed protein to nitrate contents, however, while indicative, the calculations are largely unreliable and depend on the specific feeds (type of protein and the amount), fish metabolism (influenced by the species, water temperature, growth stage etc.) and other factors. Balancing of the system is required to adjust the feeding rate and the plants that can uptake the created amount of fish waste nitrates. It is assumed that 25-30% of the nitrogen in the fish feed (present as protein) is converted to fish biomass, and the rest is excreted and nitrified for plant production. These figures can be used to approximate the nitrate needs per 1m<sup>2</sup> of your plant biomass and adjust the feeding rate/stocking density accordingly.

Several issues may arise when adjusting the feeding rates. Overfeeding can cause the decomposition of the excess food and lead to poor water quality by increasing ammonia, nitrate and nitrite levels. If in excess this can cause stress to fish. The solution to avoid this is to feed smaller portions several times a day and only provide as much food as the fish can consume within a few minutes after the feed has been added to the tank. Regular monitoring of ammonia and nitrate levels will allow you to evaluate whether the biofilter is properly working and is not being overwhelmed by excess levels of nitrogenous compounds. On the other hand, underfeeding causes stunted fish growth, and production of less waste, which reduces nutrients available for plants. Weighing fish can help in calculating accurate feed amounts for your fish population. Monitoring fish and their activity can also help in determining whether they are not stressed.

Uneaten food, when fish are overfed, can accumulate over time and start decomposing, leading to water quality issues – reduced oxygen levels and increased ammonia. One solution for this can be changing the type of food you use, instead of using sinking feed, switch to slow-sinking or floating pellets. Automatic feeders can be used to more precisely deliver the amount of feed – instead of feeding the fish once a day in large portions, use smaller portions 2-3 times a day. There should never be any food waste that has not been consumed remaining in the aquaponic system. Heterotrophic microorganisms consume substantial quantities of oxygen by consuming feed residue from overfeeding. Additionally, the level of ammonia and nitrite can be elevated to toxic levels in a relatively brief amount of time because of the decomposition of food. Lastly, the mechanical filters may become obstructed by the uneaten granules, resulting in reduced water flow and anoxic regions. Typically, fish consume their entire diet within a 30-minute timeframe. Remove any sustenance after this period. Reduce the quantity of feed administered in the future if uneaten food is discovered.

## 6. Fish health and welfare

### 6.1. Pests and diseases

The identification of external and internal parasites in fish can be effectively conducted on-site in aquaculture settings, as detailed in Terve Kala by Riitta Rahkonen (2012) (Figure 40). Bacterial infections may be diagnosed on-site; however, fish displaying atypical symptoms should be sent for laboratory analysis to confirm any suspected diseases. Detecting parasites necessitates a fundamental set of tools, which includes small scissors, a sharp scalpel, pointed tweezers, a dissection needle, small Petri dishes, and base and cover glasses for microscopy. Instruments must be cleaned following each use to prevent cross-contamination among samples.

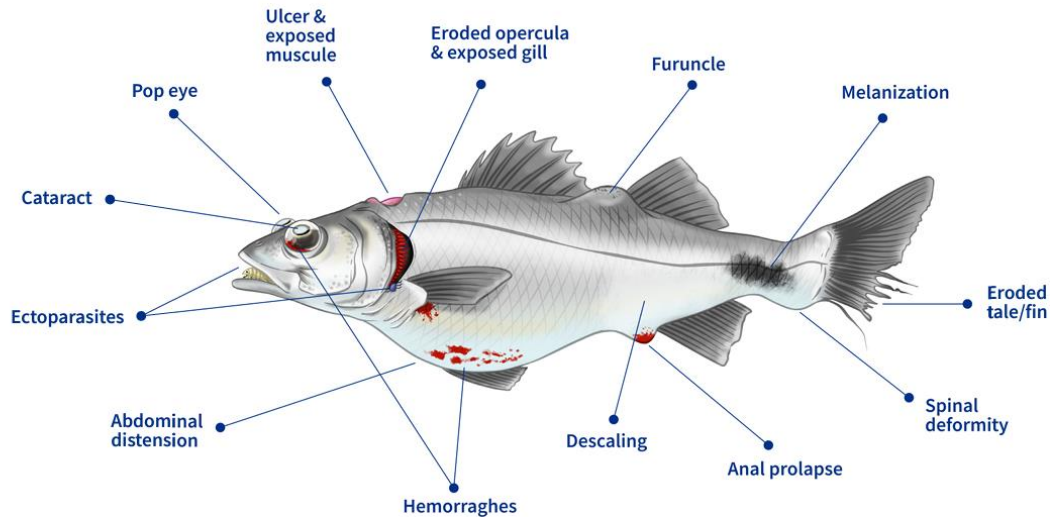

Figure 40. Common disease-affected areas of fish and deformities.

A microscope, specifically a light microscope or stereo microscope, is essential for the study of parasites. A stereo microscope offering magnification between 10 and 40x is appropriate for the observation of larger protozoa, such as *Ichthyophthirius*, which is responsible for white spot disease, *Trichodina*, and various multicellular parasites. Mucus samples from the fish's skin, gills, fins, or other external surfaces can be collected using a scalpel during routine inspection. Mucus is generally collected from regions such as beneath the pectoral fins, the sides, or tail fins, as these areas are abundant in potential parasites. Sampling small fish presents challenges, as acquiring an adequate quantity of mucus often necessitates scraping the entire lateral surface of the fish. A small quantity of collected mucus is placed on a glass slide with a drop of water from the fish tank, followed by the careful application of a cover slip. The sample must be uniformly distributed under the cover glass, as a thick mucus layer may hinder clear observation of the parasites. Fin samples can be obtained by removing the fins from the fish using tweezers. In small fish, it is possible to remove the entire fin on one side. For larger fish, the fin is excised with scissors to prevent blood from the cut tissue from contaminating the sample. The fin is subsequently positioned in a droplet of water on a microscope slide, where it is carefully spread with a needle, followed by the application of a cover slip. The collected mucus undergoes examination under the microscope to identify potential parasites. Larger protozoan parasites, such as *Ichthyophthirius* and *Trichodina*, are typically observable under a stereo microscope, whereas other parasites, including monogeneans, necessitate higher magnification for visibility. In larger fish, collecting mucus from regions such as the fins or skin may result in a higher yield of parasites.

Several fish diseases are rather common, especially in fish tanks where high stocking density is always maintained. **Ich (white spot disease)** is one of the most common protozoan diseases that fish in aquaponic systems get (Figure 41). Small white spots (cysts) showing up on the skin, fins, and gills of sick fish are the main signs. Infected fish may also act in strange ways, like rubbing



Figure 41. Ich or white spot affected fish.

## TransFarm

against the sides of the tank, moving their gills quickly (gasping for air), or sticking close to the surface. The disease can make it hard to breathe, and if isn't addressed, it can kill a lot of people. Ich is usually spread by dirty water or fish. To stop it, make sure that any new fish are kept in a separate tank for at least two weeks before being added to the main system. Keeping the water clean (by checking the temperature, pH, and dissolved oxygen) and making sure the fish are not stressed can also lower the risk. If there is an outbreak, keeping the water at about 28°C for a few days can speed up the parasite's life cycle, which makes applied medicines work better. In the worst cases, medicines made just for Ich can also be used, but care should be taken not to hurt the plants in the aquaponic system, as well as the fish by reduced DO levels<sup>10</sup>.

**Flukes or monogeneans** are parasitic flatworms that live on fish and connect to their gills, skin, or fins. Inflamed lungs, pale skin, excess mucus, and having a hard time breathing are signs of monogeneans infection. Fish that have been exposed may also appear tired, scratch things, or swim near the top to get more oxygen. Most of the time, flukes are spread by fish or water that is already infected. Before adding new fish to the system, they should be kept in a quarantine area to stop fluke infections. Check your fish often for any signs of sores or slime production that isn't normal. Keeping the water clean, keeping fish from being stressed, and keeping them from being too crowded can help lower the risk. The fish can be treated with a formalin bath or praziquantel (a pyrazine-isoquinoline derivative used as a broad anthelmintic spectrum) if flukes are found, but these chemicals should be used carefully so they don't hurt the plants and beneficial microorganisms in the aquaponic system.

**Columnaris disease** is an illness caused by *Flavobacterium columnare* that shows up on the skin, gills, or fins of fish as sores, ulcers, or a cotton-like growth (Figure 42). Infected fish may lose their hunger, swim erratically, and move their gills quickly. This disease happens more often in fish that are stressed and usually happens with bad water quality. Columnaris can be avoided by making sure the water is clean and has good filtration since the bacteria do best in places with a lot of organic waste (importance of waste sedimentation, mechanical filtration). Don't put too many fish in one area, maintain constant pH and water temperature. Antibiotics like oxytetracycline or copper sulphate can be used to treat Columnaris disease, but they may hurt the plants in an aquaponics system. To stop the bacteria from spreading, any infected fish must be taken out of the water right away.



Figure 42. Columnaris affected fish <sup>11</sup>.

A fish with **dropsy (ascites)** will have a swollen belly from excessive retaining of water (Figure 43). Fish that are infected may look fat and have scales that stick out, which is sometimes called a "pinecone" appearance. This problem usually shows up as a sign of a deeper infection or organ failure, like kidney

<sup>10</sup> <https://startlife.nl/bioventure-sundew-raises-1-4m-euro-in-seed-financing/>

<sup>11</sup> Declercq, A. M., Haesebrouck, F., Van den Broeck, W., Bossier, P., & Decostere, A. (2013). Columnaris disease in fish: a review with emphasis on bacterium-host interactions. *Veterinary research*, 44, 1-17.





Figure 43. Dropsy affected fish.

or liver disease. It can be caused by either bacteria or viruses. Bad water quality or viral infections are common causes, so it is important to keep water parameters constant and optimal for specific species. Dropsy can spread easily, so it's important to get sick fish out of the system immediately after the infection has been noticed. Dropsy can't be cured directly, but the immune systems of healthy fish should be supported by better water quality, less stress, and well-balanced food.

**Fin rot** is a bacterial disease that makes the fish's fins and tail break down (Figure 44). Fins that are wearing away or breaking, fin bases that are turning red, and a general look of decay are signs of this disease. Fish that are affected may also appear tired or eat less. Fin rot is usually caused by bad water quality or physical damage to the fish. It can be avoided by keeping the water clean and filtered and keeping the fish from getting hurt – no sharp corners, or obstacles within the fish tank. Fish with fin rot can be treated with antibiotics or antibacterial treatments like salt baths<sup>12</sup>.



Figure 44. Fin rot affected trout.



Figure 45. Fish lice affected fish.

**Fish lice (argulusosis, fish louse)** are external parasites that stick to fish's skin, fins, or lungs and irritate, inflame, and leave marks that can be seen (Figure 45). Infected fish may rub against the sides of their tanks or swim very quickly. They may also lose scales or get cuts where the lice are attached. To keep fish lice away, it's important to keep new fish in a quarantine area before adding them to the system and to check fish for signs of external parasites. If fish lice become a problem, they can be removed by hand or treated with certain medicines that kill parasites. It's important to be careful with poisons

because they can hurt the plants in the aquaponic system and the overall quality of the fish if consumed as food<sup>13</sup>.

It is important to keep an eye on and adjust water quality factors like pH, temperature, ammonia, nitrites, nitrates and dissolved oxygen daily to make sure they stay in the optimal ranges for the species being grown in an aquaponic system. New fish should be quarantined for at least two weeks before they can be added to the system. This helps stop the spread of diseases. To keep fish from overcrowding, which can cause stress and make it easier for diseases to spread, it's also important to carefully control the number of fish in each 100 L of water. A general rule of thumb is 1-2 kg of fish per 100 litres of water. Filtration systems need to be properly maintained to get rid of waste and stop

<sup>12</sup> Bruno, D. W., Noguera, P. A., & Poppe, T. T. (2013). A colour atlas of salmonid diseases (Vol. 91). Springer Science & Business Media.

<sup>13</sup> <https://fishfixsrilanka.lk/2023/02/12/argulus-infection-in-fish-symptoms-treatment-and-prevention/>

dangerous bacteria from building up. The fish's immune system needs to be kept strong by avoiding sudden changes in water quality or feeding times and reducing stress. Giving the fish a balanced food that is right for its species also helps it grow well and resist disease, food is the main source of ingredients in fish diets that can help in maintaining proper antioxidant levels and immunity responses.

## 6.2. Stocking density

The quantity of fish maintained per unit volume of water, or fish stocking density, is a critical factor in the maintenance of a healthy system and the attainment of optimal productivity in aquaponics (Figure 46). The overall effectiveness of the aquaponic system is influenced by the stocking density, which impacts fish growth, health, feed efficiency, and water quality. The optimal stocking density is contingent upon the species, water management practices, and system design, and it can be difficult to achieve the appropriate equilibrium. An excessively high density can result in stress, competition, and waste accumulation, while an excessively low density may contribute to the underutilisation of nutrients and less efficient plant growth. The stocking density of fish in an aquaponics system is determined by a variety of factors, such as the intended plant output, tank size, fish species, and the biofiltration unit's overall capacity. A standard practice is to stock fish at a rate that is compatible with the biofilter and plant plots. This results in stocking densities of 20–40 kg of fish per cubic metre of water for numerous systems. Nevertheless, the extent of this variability is contingent upon the fish's development stage and species. A biofiltration system that can process the increased wastes and maintain water quality parameters within safe limits, such as ammonia, nitrite, and nitrate, is necessary to accommodate a higher density.

Depending on the fish species, the stocking density can vary, below are the most common species grown in aquaponics and their respective specifics related to the stocking density.

### **Tilapia (*Oreochromis niloticus*)**

The durability, tolerance to variable water conditions, and rapid growth rate of tilapia make it one of the most popular fish species for aquaponics. Tilapia can flourish in comparatively high stocking densities in small- to medium-scale systems without experiencing adverse health effects. Tilapia are frequently maintained at densities of 20–30 kg per cubic metre in recirculating aquaponics systems (RAS). Nevertheless, tilapia can be stocked at a rate of 40–50 kg per cubic metre in systems that are maintained, with frequent water quality monitoring and intensive biofiltration. For example, a system that contains 1000 L of water can effectively sustain approximately 20–30 adult tilapia with an average weight of 500 g each, if filtration and aeration are sufficient.

### **Rainbow Trout (*Oncorhynchus mykiss*)**

Rainbow trout is a cool-water species that necessitates consistent water quality and high oxygen levels, which makes it somewhat challenging but rewarding in aquaponics systems. Rainbow trout are typically supplied at lower densities than tilapia, with stocking rates ranging from 10–20 kg per cubic metre, because of their sensitivity to water conditions. Trout are also known for their rapid growth, but they require temperatures that are maintained between 10°C and 18°C to ensure excellent health. A balanced load that supports both fish health and plant growth can be achieved by stocking 15–20 rainbow trout, each weighing approximately 400 g, in a 1000 L system. An efficient filtration system and frequent monitoring are essential for trout, as they are sensitive to ammonia and nitrite levels.

### **Catfish (*Clarias gariepinus* and *Ictalurus punctatus*)**

Both African catfish (*Clarias gariepinus*) and channel catfish (*Ictalurus punctatus*) are capable of withstanding variable water quality and decreased oxygen levels, rendering them suitable for high-

TransFarm

density stocking in aquaponics. Catfish can be maintained at a density of 30–40 kg per cubic metre in intensive systems. African catfish are capable of withstanding even higher densities while breathing atmospheric oxygen. A 1000 L system can accommodate approximately 30–40 catfish, with an average weight of 500 g, provided that the system is equipped with a robust biofiltration system and an aeration mechanism. The system must be capable of accommodating the supplementary ammonia burden, as catfish have a high rate of waste production.

**Barramundi (*Lates calcarifer*)**

Barramundi is a warm-water fish that is particularly popular in aquaponics, particularly in regions with milder climates. These fish exhibit a high tolerance for fluctuations in water quality and develop rapidly. However, they necessitate monitoring due to their high waste production. In systems with consistent maintenance and robust filtration, barramundi is typically maintained at a density of 15–25 kg per cubic metre. If the water temperature is maintained at 26–30°C and the dissolved oxygen levels are adequate, approximately 15–20 barramundi with an average weight of 600 g can flourish in a 1000 L tank.

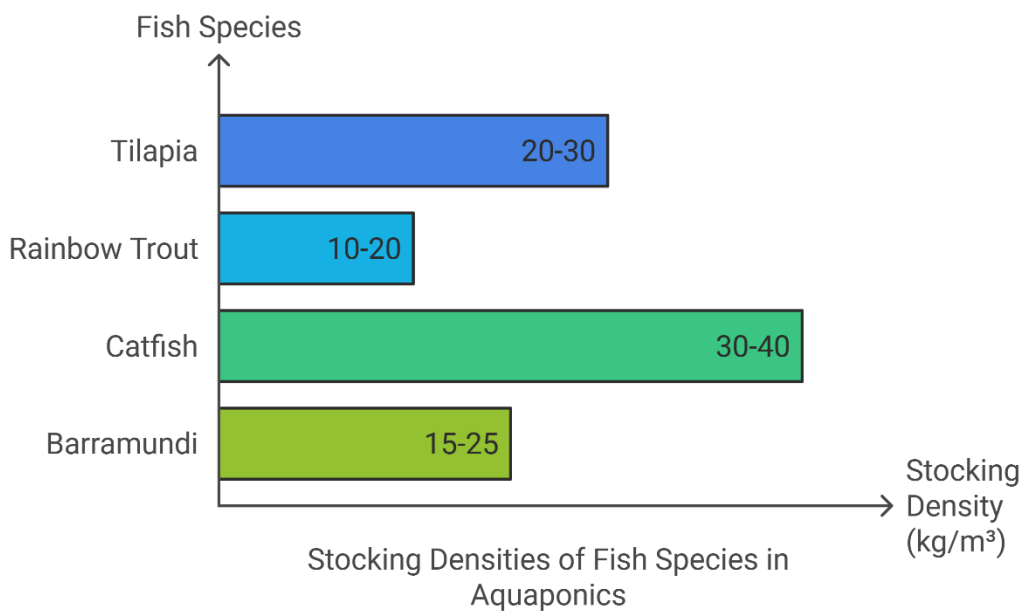

Figure 46. Fish stocking density of different species commonly grown in aquaponics.

The nutrient requirements of the plants must be met while the stocking density in aquaponics is balanced to prevent the compromise of fish health. An increase in ammonia production can result from high stocking densities, which, in the absence of sufficient biofiltration, can increase the stress levels and disease susceptibility of fish. Additionally, the waste output is influenced by the quality and frequency of nutrition, as higher protein diets generate a greater amount of nitrogenous waste. To prevent overfeeding, which can negatively impact water quality and promote the development of pathogens, the feeding schedule should be adjusted according to the biomass of the fish population.

For example, tilapia that are fed a diet containing 30–35% protein will produce an adequate amount of nitrogen to support plant growth without overburdening the biofilter. Nevertheless, trout and barramundi necessitate diets with a higher protein content (40–50%), which generates a greater amount of detritus. To preserve stable water conditions, it is recommended that these fish be fed smaller quantities more frequently, thereby ensuring that refuse levels remain within acceptable limits.

### TransFarm

The biofilter's capacity is essential for determining the population density. Nitrifying bacteria are the primary function of a biofilter, as they convert noxious ammonia into nitrite and subsequently nitrate, which is a usable nutrient for plants. The utmost anticipated ammonia output from fish at peak biomass must be used to determine the size of biofilters. Furthermore, the population density is substantially influenced by tank design variables, including water flow rate, tank depth, and aeration. Round tanks with a central drain are optimal for high-density systems, as they facilitate waste removal and prevent refuse from settling at the bottom, thereby promoting improved water quality.

The optimal stocking density in aquaponics is contingent upon the biofiltration capacity, system design, and species characteristics. It is necessary to strike a balance between the need to maximise fish biomass for nutrient production and the need to ensure that the water quality is adequate to prevent health hazards. The design of a system must consider the distinct challenges that each species presents, such as the high oxygen requirements of trout and the adaptability of tilapia. To establish a sustainable and harmonious ecosystem, aquaponics practitioners must regulate stocking density, feed rates, and system parameters to promote the development of productive plants and the health of fish.

## References

- Baganz, G. F., Junge, R., Portella, M. C., Goddek, S., Keesman, K. J., Baganz, D., ... & Kloas, W. (2022). The aquaponic principle—It is all about coupling. *Reviews in Aquaculture*, 14(1), 252-264.
- Bernstein S. (2011). *Aquaponic Gardening: a step-by-step guide to raising vegetables and fish together*. New Society Publishers, Canada.
- Bittsánszky, A., Gyulai, G., Junge, R., Schmutz, Z. & Komives, T. (2015). Plant protection in ecocycle-based agricultural systems: Aquaponics as an example. In *Proceedings of the International Plant Protection Congress (IPPC)*, Berlin, Germany Vol. 2427.
- Bracino, A. A., Concepcion, R. S., Dadios, E. P., & Vicerra, R. R. P. (2020, December). Biofiltration for recirculating aquaponic systems: a review. In *2020 IEEE 12th International Conference on Humanoid, Nanotechnology, Information Technology, Communication and Control, Environment, and Management (HNICEM)* (pp. 1-6). IEEE.
- Colt, J., Schuur, A. M., Weaver, D., & Semmens, K. (2022). Engineering design of aquaponics systems. *Reviews in Fisheries Science & Aquaculture*, 30(1), 33-80.
- Filep, R. M., Diaconescu, S., Marin, M., Bădulescu, L., & Nicolae, C. G. (2016). Case study on water quality control in an aquaponic system. *Current Trends in Natural Sciences* Vol, 5(9), 06-09.
- Folorunso, E. A., Roy, K., Gebauer, R., Bohatá, A., & Mraz, J. (2021). Integrated pest and disease management in aquaponics: A metadata-based review. *Reviews in Aquaculture*, 13(2), 971-995.
- Goddek, S., Delaide, B., Mankasingh, U., Ragnarsdottir, K. V., Jijakli, H., & Thorarinsdottir, R. (2015). Challenges of sustainable and commercial aquaponics. *Sustainability*, 7(4), 4199-4224.
- Goddek, S., Joyce, A., Kotzen, B., & Dos-Santos, M. (2019). Aquaponics and global food challenges. *Aquaponics food production systems: Combined aquaculture and hydroponic production technologies for the future*, 3-17.
- Gosh, K., & Chowdhury, S. (2019). Review of aquaponics system: searching for a technically feasible and economically profitable aquaponics system. *Journal of Agricultural, Environmental and Consumer Sciences*, 19, 5-13.
- Joyce, A., Timmons, M., Goddek, S., & Pentz, T. (2019). Bacterial relationships in aquaponics: new research directions. *Aquaponics food production systems: combined aquaculture and hydroponic production technologies for the future*, 145-161.
- Junge, R., Antenen, N. (2020). *Aquaponics textbook*. AquaTeach.
- Kasozi, N., Abraham, B., Kaiser, H., & Wilhelmi, B. (2021). The complex microbiome in aquaponics: significance of the bacterial ecosystem. *Annals of Microbiology*, 71(1), 1-13.
- Kasozi, N., Tandlich, R., Fick, M., Kaiser, H., & Wilhelmi, B. (2019). Iron supplementation and management in aquaponic systems: A review. *Aquaculture Reports*, 15, 100221.
- Krastanova, M., Sirakov, I., Ivanova-Kirilova, S., Yarkov, D., & Orozova, P. (2022). Aquaponic systems: Biological and technological parameters. *Biotechnology & Biotechnological Equipment*, 36(1), 305-316.

TransFarm

- Kushwaha, J., Priyadarsini, M., Rani, J., Pandey, K. P., & Dhoble, A. S. (2023). Aquaponic trends, configurations, operational parameters, and microbial dynamics: A concise review. *Environment, Development and Sustainability*, 1-34.
- Lennard, W., & Goddek, S. (2019). Aquaponics: the basics. *Aquaponics food production systems*, 113.
- Licamele, J. (2009). Biomass production and nutrient dynamics in an aquaponics system (Doctoral dissertation, The University of Arizona).
- Maucieri, C., Nicoletto, C., Junge, R., Schmautz, Z., Sambo, P., & Borin, M. (2018). Hydroponic systems and water management in aquaponics: A review. *Italian Journal of Agronomy*, 13(1), 1-11.
- Nichols, M. A., & Savidov, N. A. (2011, May). Aquaponics: a nutrient and water efficient production system. In *II International Symposium on Soilless Culture and Hydroponics 947* (pp. 129-132).
- Okomoda, V. T., Oladimeji, S. A., Solomon, S. G., Olufeagba, S. O., Ogah, S. I., & Ikhwanuddin, M. (2023). Aquaponics production system: A review of historical perspective, opportunities, and challenges of its adoption. *Food science & nutrition*, 11(3), 1157-1165.
- Pinho, S. M., David, L. H., Garcia, F., Keesman, K. J., Portella, M. C., & Goddek, S. (2021). South American fish species suitable for aquaponics: a review. *Aquaculture international*, 29(4), 1427-1449.
- Rakocy, J. E. (2012). Aquaponics—integrating fish and plant culture. *Aquaculture production systems*, 344-386.
- Resh, H.M. (2013). *Hydroponic Food Production: A Definitive Guidebook for the Advanced Home Gardener and the Commercial Hydroponic Grower* (7th edition). CRC Press, Boca Raton.
- Robaina, L., Pirhonen, J., Mente, E., Sánchez, J., & Goosen, N. (2019). Fish diets in aquaponics. *Aquaponics Food Production Systems: Combined Aquaculture and Hydroponic Production Technologies for the Future*, 333-352.
- Salleneave, R. (2016). Important water quality parameters in aquaponics systems. College of Agricultural, Consumer and Environmental Sciences.
- Schmautz, Z., Graber, A., Jaenicke, S., Goesmann, A., Junge, R. & Smits, T.H. (2017). Microbial diversity in different compartments of an aquaponics system. *Archives of Microbiology* 199 (4): 613-620.
- Shaw, C., Knopf, K., & Kloas, W. (2022). Fish feeds in aquaponics and beyond: A novel concept to evaluate protein sources in diets for circular multitrophic food production systems. *Sustainability*, 14(7), 4064.
- Shumet, A. (2021). Aquaponics: A Sustainable Solution for Health, Economy, and Society-A Comprehensive Review. *Aquaponics*, 1(2).
- Somerville, C., Cohen, M., Pantanella, E., Stankus, A., & Lovatelli, A. (2014). Small-scale aquaponic food production: integrated fish and plant farming. *FAO Fisheries and aquaculture technical paper*, (589), I.
- Stathopoulou, P., Berillis, P., Levizou, E., Sakellariou-Makrantonaki, M., Kormas, A. K., Aggelaki, A., ... & Mente, E. (2018, November). Aquaponics: A mutually beneficial relationship of fish, plants and bacteria. In *Proceedings of the 3rd International Congress on Applied Ichthyology & Aquatic Environment*, Volos, Greece (pp. 8-11).

### TransFarm

Stouvenakers, G., Dapprich, P., Massart, S., & Jijakli, M. H. (2019). Plant pathogens and control strategies in aquaponics. *Aquaponics food production systems*, 353-378.

Tezel M. (2009). *Aquaponics common sense guide*. Unknown publisher, United States of America.

The European Parliament and the Council of the European Union 2009. Directive 2009/128/EC of the European Parliament and of the Council of 21 October 2009 establishing a framework for Community action to achieve the sustainable use of pesticides. *Official Journal of the European Union* L 309/71.

Tyson, R. V., Simonne, E. H., White, J. M., & Lamb, E. M. (2004, December). Reconciling water quality parameters impacting nitrification in aquaponics: the pH levels. In *Proceedings of the Florida State Horticultural Society* (Vol. 117, pp. 79-83).

Veludo, M., Hughes, A., & Le Blan, B. (2012). *Introduction to Aquaponics: A Key to Sustainable Food Production*. Survey of Aquaponics in Europe. Water.

Villarroel, M., Mariscal-Lagarda, M. M., & Franco, G. (2021). 1. an introduction to aquaponics. *Biology and Aquaculture of Tilapia*.

Wirza, R., & Nazir, S. (2021). Urban aquaponics farming and cities-a systematic literature review. *Reviews on environmental health*, 36(1), 47-61.

Yavuzcan Yildiz, H., Robaina, L., Pirhonen, J., Mente, E., Domínguez, D., & Parisi, G. (2017). Fish welfare in aquaponic systems: its relation to water quality with an emphasis on feed and faeces—a review. *Water*, 9(1), 13.

Yep, B., & Zheng, Y. (2019). Aquaponic trends and challenges—A review. *Journal of Cleaner Production*, 228, 1586-1599.

[FishStat - Fisheries and Aquaculture \(fao.org\)](https://www.fao.org/)

[Fiskarter-RAS.pdf \(vattenbrukscentrumost.se\)](#)

Persson, B *et al* 2022 *Akvaponihandboken*

<https://gogreenaquaponics.com/blogs/news/guide-to-raising-yellow-perch-in-aquaponics-systems>

[https://jukuri.luke.fi/bitstream/handle/10024/531516/Loppuraportti\\_final.pdf?sequence=1&isAllowed=y](https://jukuri.luke.fi/bitstream/handle/10024/531516/Loppuraportti_final.pdf?sequence=1&isAllowed=y)

Berglöf, K *et al* 2018 *Handbok för landbaserad fiskodling- Fisk i hus*

[\(PDF\) Domestication of the Eurasian Perch \(Perca fluviatilis\) \(researchgate.net\)](#)

[Västerås \(vuef.se\)](#)

[Microsoft Word - rp348.doc \(luke.fi\)](#)

© FAO 2024. *Sander lucioperca*. Cultured Aquatic Species Information Programme. Text by Zakeś, Z.. In: *Fisheries and Aquaculture*. Rome. Updated 2012-03-16 [Cited Wednesday, July 3rd 2024].

[https://www.fao.org/fishery/en/culturedspecies/sander\\_lucioperca/en](https://www.fao.org/fishery/en/culturedspecies/sander_lucioperca/en)

[Production of market-size European strain Atlantic salmon \( Salmo salar \) in land-based freshwater closed containment aquaculture systems \(sciencedirectassets.com\)](#)

<https://alchetron.com/>

**TransFarm**

[https://www.fao.org/fishery/en/culturedspecies/sander\\_lucioperca/en](https://www.fao.org/fishery/en/culturedspecies/sander_lucioperca/en)

[Production of market-size European strain Atlantic salmon \( \*Salmo salar\* \) in land-based freshwater closed containment aquaculture systems \(sciencedirectassets.com\)](#)